MCC DAQ HAT Library Documentation

Release 1.5.0

Measurement Computing

Dec 28, 2023

CONTENTS

1	Hardware Overview	1
1.1	Hardware Compatibility	1
1.2	MCC 118	1
1.2.1	Board components	2
1.2.1.1	Screw terminals	2
1.2.1.2	Address jumpers	2
1.2.1.3	Status LED	2
1.2.1.4	Header connector	3
1.2.2	Functional block diagram	3
1.2.3	Functional details	3
1.2.3.1	Scan clock	3
1.2.3.2	Trigger	4
1.2.4	Firmware updates	4
1.2.5	MCC 118-OEM	5
1.2.6	Specifications	5
1.3	MCC 128	10
1.3.1	Single Ended Input configuration	10
1.3.2	Differential Input Configuration	11
1.3.3	Board components	11
1.3.3.1	Screw terminals	11
1.3.3.2	Address jumpers	12
1.3.3.3	Status LED	12
1.3.3.4	Header connector	12
1.3.4	Functional block diagram	12
1.3.5	Functional details	12
1.3.5.1	Scan clock	12
1.3.5.2	Trigger	13
1.3.6	Firmware updates	13
1.3.7	MCC 128-OEM	14
1.3.8	Specifications	14
1.4	MCC 134	20
1.4.1	Board components	20
1.4.1.1	Screw terminals	20
1.4.1.2	Address jumpers	20
1.4.1.3	Status LED	20
1.4.1.4	Header connector	21
1.4.2	Functional block diagram	21
1.4.3	Functional details	21
1.4.3.1	Best practices for accurate thermocouple measurements	21
1.4.4	Specifications	22

1.5	MCC 152	29
1.5.1	Board components	29
1.5.1.1	Screw terminals	29
1.5.1.2	Address jumpers	30
1.5.1.3	DIO Power jumper (W3)	30
1.5.1.4	Status LED	30
1.5.1.5	Header connector	30
1.5.2	Functional block diagram	30
1.5.3	Functional details	31
1.5.3.1	Mixing 3.3V and 5V digital inputs	31
1.5.4	Specifications	31
1.6	MCC 172	35
1.6.1	Board components	35
1.6.1.1	10-32 coaxial connectors	35
1.6.1.2	Screw terminals	35
1.6.1.3	Address jumpers	36
1.6.1.4	Status LED	36
1.6.1.5	Header connector	36
1.6.2	Functional block diagram	36
1.6.3	Functional details	36
1.6.3.1	ADC clock	36
1.6.3.2	Trigger	37
1.6.3.3	Alias Rejection	37
1.6.4	Firmware updates	37
1.6.5	Specifications	37
2	Installing the DAQ HAT board	43
2.1	Installing a single board	43
2.2	Installing multiple boards	44
3	Installing and Using the Library	47
3.1	Installation	47
3.2	Firmware Updates	48
3.2.1	MCC 118	48
3.3	Creating a C program	48
3.4	Creating a Python program	49
4	C Library Reference	51
4.1	Global functions and data	51
4.1.1	Functions	51
4.1.2	Data types and definitions	53
4.1.2.1	HAT IDs	53
4.1.2.2	Result Codes	54
4.1.2.3	HatInfo structure	55
4.1.2.4	Analog Input / Scan Option Flags	55
4.1.2.5	Scan Status Flags	56
4.1.2.6	Trigger Modes	56
4.2	MCC 118 functions and data	57
4.2.1	Functions	57
4.2.2	Data definitions	64
4.2.2.1	Device Info	64
4.3	MCC 128 functions and data	65
4.3.1	Functions	65
4.3.2	Data definitions	73

4.3.2.1	Device Info	73
4.3.2.2	Analog Input Modes	74
4.3.2.3	Analog Input Ranges	74
4.4	MCC 134 functions and data	75
4.4.1	Functions	75
4.4.2	Data definitions	79
4.4.2.1	Device Info	79
4.4.2.2	Thermocouple Types	80
4.5	MCC 152 functions and data	81
4.5.1	Functions	81
4.5.2	Data types and definitions	89
4.5.2.1	Device Info	89
4.5.2.2	DIO Config Items	89
4.6	MCC 172 functions and data	90
4.6.1	Functions	90
4.6.2	Data definitions	100
4.6.2.1	Device Info	100
4.6.2.2	Source Types	100
5	Python Library Reference	101
5.1	Global methods and data	101
5.1.1	Methods	101
5.1.2	Data	103
5.1.2.1	Hat IDs	103
5.1.2.2	Trigger modes	104
5.1.2.3	Scan / read option flags	104
5.1.3	HatError class	104
5.2	MCC 118 class	105
5.2.1	Methods	105
5.3	MCC 128 class	112
5.3.1	Methods	112
5.3.2	Data	121
5.3.2.1	Analog input modes	121
5.3.2.2	Analog input ranges	121
5.4	MCC 134 class	122
5.4.1	Methods	122
5.4.2	Data	127
5.4.2.1	Thermocouple types	127
5.5	MCC 152 class	127
5.5.1	Methods	127
5.5.2	Data	140
5.5.2.1	DIO Config Items	140
5.6	MCC 172 class	140
5.6.1	Methods	140
5.6.2	Data	151
5.6.2.1	Source types	151
Index		153

HARDWARE OVERVIEW

The MCC DAQ HATs are Raspberry Pi add-on boards (Hardware Attached on Top). They adhere to the Raspberry Pi HAT specification, but also extend it to allow stacking up to 8 MCC boards on a single Raspberry Pi.

C and Python libraries, documentation, and examples are provided to allow you to develop your own applications.

1.1 Hardware Compatibility

The MCC DAQ HATs are compatible with all Raspberry Pi models with the 40-pin GPIO header (not the original Pi 1 A or B with the 26-pin header.) They are generally not compatible with any other brand of Raspberry Pi HAT or add-on board that attaches to the GPIO header, or devices that use the Raspberry Pi SPI interface.

In particular, LCD displays that use the GPIO header (not HDMI) usually use the SPI interface and will prevent the DAQ HATs from working. Even if the display is removed, the driver is probably still loaded by `/boot/config.txt` and will cause issues with the DAQ HATs. If you have a problem with your device and have used a GPIO header display with your Raspberry Pi then consult your display hardware documentation for how to remove the driver.

The specific pins used by each DAQ HAT are documented in the electrical specifications for that device.

1.2 MCC 118

The MCC 118 is an 8-channel analog voltage input board with the following features:

- 12-bit, 100 kS/s A/D converter
- ± 10 V single-ended analog inputs
- Factory calibration with ± 20.8 mV input accuracy
- Bidirectional scan clock
- Onboard sample buffers
- Digital trigger input

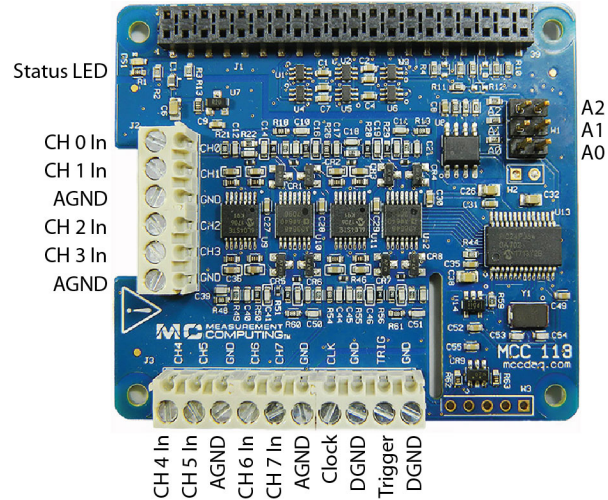

1.2.1 Board components

1.2.1.1 Screw terminals

- **CH 0 In** to **CH 7 In** (CHx): Single-ended analog input terminals.
- **Clock** (CLK): Bidirectional terminal for scan clock input / output. Set the direction with software. Set for input to clock the scans with an external clock signal, or output to use the internal scan clock.
- **Trigger** (TRIG): External digital trigger input terminal. The trigger mode is software configurable for edge or level sensitive, rising or falling edge, high or low level.
- **AGND** (GND): Common ground for the analog input terminals.
- **DGND** (GND): Common ground for the clock and trigger terminals.

1.2.1.2 Address jumpers

- **A0** to **A2**: Used to identify each HAT when multiple boards are connected. The first HAT connected to the Raspberry Pi must be at address 0 (no jumper). Install jumpers on each additional connected board to set the desired address. Refer to the [Installing multiple boards](#) topic for more information about the recommended addressing method.

1.2.1.3 Status LED

The LED turns on when the board is connected to a Raspberry Pi with external power applied and flashes when communicating with the board. The LED may be blinked by the user.

1.2.1.4 Header connector

The board header is used to connect with the Raspberry Pi. Refer to *Installing the DAQ HAT board* for more information about the header connector.

1.2.2 Functional block diagram

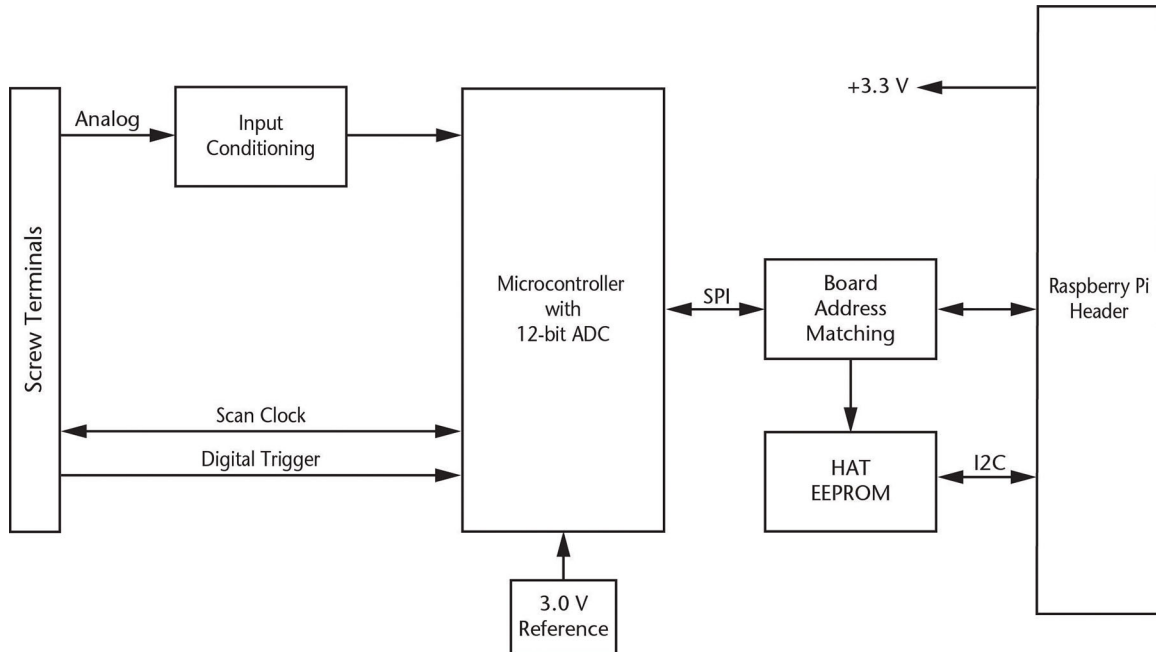

1.2.3 Functional details

1.2.3.1 Scan clock

The clock input / output (terminal CLK) is used to output the internal scan clock or apply an external scan clock to the device. The clock input signal may be a 3.3V or 5V TTL or CMOS logic signal, and the output will be 3.3V LVCMOS. A scan occurs for each rising edge of the clock, acquiring one sample from each of the selected channels in the scan. For example, when scanning channels 0, 1, and 2 the conversion activity will be:

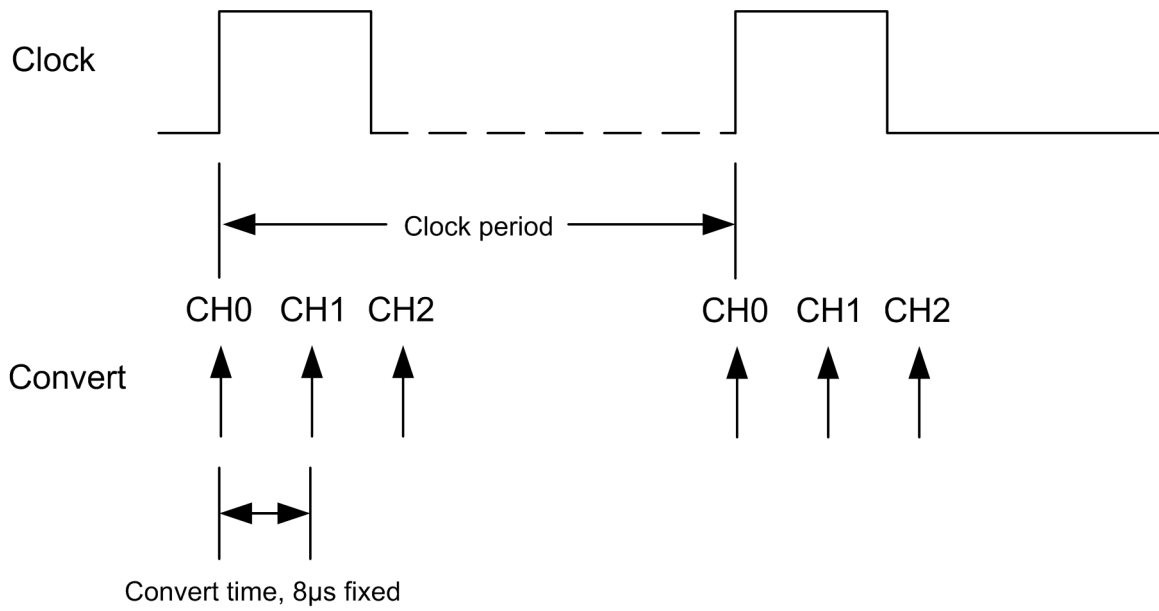

1.2.3.2 Trigger

The trigger input (terminal TRIG) is used to hold off the beginning of an analog input scan until the desired condition is met at the trigger input. The trigger input signal may be a 3.3V or 5V TTL or CMOS logic signal. The input condition may be rising edge, falling edge, high level, or low level.

1.2.4 Firmware updates

Use the firmware update tool to update the firmware on your MCC 118 board(s). The “0” in the example below is the board address. Repeat the command for each MCC 118 address in your board stack. This example demonstrates how to update the firmware on the MCC 118 that is installed at address 0:

```
mcc118_firmware_update 0 ~/daqhats/tools/MCC_118.hex
```

1.2.5 MCC 118-OEM

An OEM version is available that is designed with (unpopulated) header connectors instead of screw terminals. The board accepts 1x6 and 1x10 0.1" spacing header connectors. The MCC 118-OEM is functionally equivalent to the standard version. Refer to the Electrical Specifications for connector information.

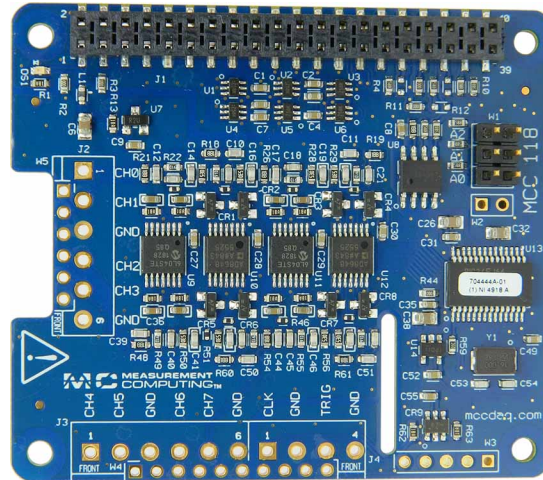

1.2.6 Specifications

All specifications are subject to change without notice.

Typical for 25 °C unless otherwise specified.

Specifications in *italic text* are guaranteed by design.

Analog input

Table 1. General analog input specifications

Parameter	Conditions	Specification
A/D converter type		Successive approximation
ADC resolution		12 bits
Number of channels		8 single-ended
Input voltage range		± 10 V
<i>Absolute maximum input voltage</i>	<i>CHx relative to AGND</i>	<input type="checkbox"/> ± 25 V max (power on) <input type="checkbox"/> ± 25 V max (power off)
<i>Input impedance</i>		<input type="checkbox"/> 1 M Ω (power on) <input type="checkbox"/> 1 M Ω (power off)
<i>Input bias current</i>	<i>10 V input</i>	-12 μ A
	<i>0 V input</i>	2 μ A
	<i>-10 V input</i>	12 μ A
<i>Monotonicity</i>		<i>Guaranteed</i>
Input bandwidth	Small signal (-3 dB)	150 kHz
Maximum working voltage	Input range relative to AGND	± 10.1 V max
Crosstalk	Adjacent channels, DC to 10 kHz	-75 dB
Input coupling		DC
Recommended warm-up time		1 minute min
Sampling rate, hardware paced	Internal scan clock	0.004 S/s to 100 kS/s, software-selectable
	External scan clock	100 kS/s max
Sampling mode		One A/D conversion for each configured channel per clock
Conversion time	Per channel	8 μ s
Scan clock source		<input type="checkbox"/> Internal scan clock <input type="checkbox"/> External scan clock input on terminal CLK
Channel queue		Up to eight unique, ascending channels
Throughput, Raspberry Pi [®] 2 / 3 / 4	Single board	100 kS/s max
	Multiple boards	Up to 320 kS/s aggregate (Note 1)
Throughput, Raspberry Pi A+ / B+	Single board	Up to 100 kS/s (Note 1)
	Multiple boards	Up to 100 kS/s aggregate (Note 1)

Note 1: Depends on the load on the Raspberry Pi processor. The highest throughput may be achieved by using a Raspberry Pi 3 B+.

Accuracy

Analog input DC voltage measurement accuracy

Table 2. DC Accuracy components and specifications. All values are (\pm)

Range	Gain error, max (% of reading)	Offset error, max (mV)	Absolute accuracy at Full Scale (mV)	Gain temperature coefficient (% reading/ $^{\circ}$ C)	Offset temperature coefficient (mV/ $^{\circ}$ C)
± 10 V	0.098	11	20.8	0.016	0.87

Noise performance

For the peak to peak noise distribution test, the input channel is connected to AGND at the input terminal block, and 12,000 samples are acquired at the maximum throughput.

Table 3. Noise performance specifications

Range	Counts	LSBrms
± 10 V	5	0.76

External digital trigger

Table 4. External digital trigger specifications

Parameter	Conditions	Specification
Trigger source		TRIG input
Trigger mode		Software configurable for rising or falling edge, or high or low level
Trigger latency	Internal scan clock	1 μ s max
	External scan clock	1 μ s + 1 scan clock cycle max
Trigger pulse width		125 ns min
Input type		Schmitt trigger, weak pull-down to ground (approximately 10 K)
Input high voltage threshold		2.64 V min
Input low voltage threshold		0.66 V max
Input voltage limits		5.5 V absolute max -0.5 V absolute min 0 V recommended min

External scan clock input/output

Table 5. External scan clock I/O specifications

Parameter	Specification
Terminal name	CLK
Terminal types	Bidirectional, defaults to input when not sampling analog channels
Direction (software-selectable)	Output: Outputs internal scan clock; active on rising edge Input: Receives scan clock from external source; active on rising edge
Input clock rate	100 kHz max
Input clock pulse width	400 ns min
Input type	Schmitt trigger, weak pull-down to ground in input mode (approximately 10 K), protected with 150 Ω series resistor
Input high voltage threshold	2.64 V min
Input low voltage threshold	0.66 V max
Input voltage limits	5.5 V absolute max -0.5 V absolute min 0 V recommended min
Output high voltage	3.0 V min (IOH = -50 μ A) 2.65 V min (IOH = -3 mA)
Output low voltage	0.1 V max (IOL = 50 μ A) 0.8 V max (IOL = 3 mA)
Output current	\pm 3 mA max

Memory

Table 6. Memory specifications

Parameter	Specification
Data FIFO	7 K (7,168) analog input samples
Non-volatile memory	4 KB (ID and calibration storage, no user-modifiable memory)

Power

Table 7. Power specifications

Parameter	Conditions	Specification
Supply current, 3.3V supply	Typical	35 mA
	Maximum	55 mA

Interface specifications

Table 8. Interface specifications

Parameter	Specification
Raspberry Pi TM GPIO pins used	GPIO 8, GPIO 9, GPIO 10, GPIO 11 (SPI interface) ID_SD, ID_SC (ID EEPROM) GPIO 12, GPIO 13, GPIO 26, (Board address)
Data interface type	SPI slave device, CE0 chip select
SPI mode	1
SPI clock rate	10 MHz, max

Environmental

Table 9. Environmental specifications

Parameter	Specification
Operating temperature range	0 °C to 55 °C
Storage temperature range	-40 °C to 85 °C
Humidity	0% to 90% non-condensing

Mechanical

Table 10. Mechanical specifications

Parameter	Specification
Dimensions (L × W × H)	65 × 56.5 × 12 mm (2.56 × 2.22 × 0.47 in.) max

User connectors

Table 11. Screw terminal connector specifications

Parameter	Specification
Connector type	Screw terminal
Wire gauge range	16 AWG to 30 AWG

Table 12. Optional header connector (MCC 118-OEM) specifications

Parameter	Specification
Connector type	User supplied and user installed header
W5 header footprint	1×6, 0.1" spacing
W4 header footprint	1×10, 0.1" spacing

Table 13. Connector pinout

Connector J2 or W5 (OEM version)		
Pin	Signal name	Pin description
1	CH0	Channel 0
2	CH1	Channel 1
3	GND	Analog ground
4	CH2	Channel 2
5	CH3	Channel 3
6	GND	Analog ground
Connector J3 or W4 (OEM version)		
Pin	Signal name	Pin description
7	CH4	Channel 4
8	CH5	Channel 5
9	GND	Analog ground
10	CH6	Channel 6
11	CH7	Channel 7
12	GND	Analog ground
13	CLK	Scan clock input / output
14	GND	Digital ground
15	TRIG	Digital trigger input
16	GND	Digital ground

1.3 MCC 128

The MCC 128 is an analog voltage input board with the following features:

- 16-bit, 100 kS/s A/D converter
- Single-ended and differential input modes
- 4 differential or 8 single-ended channels
- ± 10 V, ± 5 V, ± 2 V, and ± 1 V input ranges
- Factory calibration
- Bidirectional scan clock
- Onboard sample buffers
- Digital trigger input

1.3.1 Single Ended Input configuration

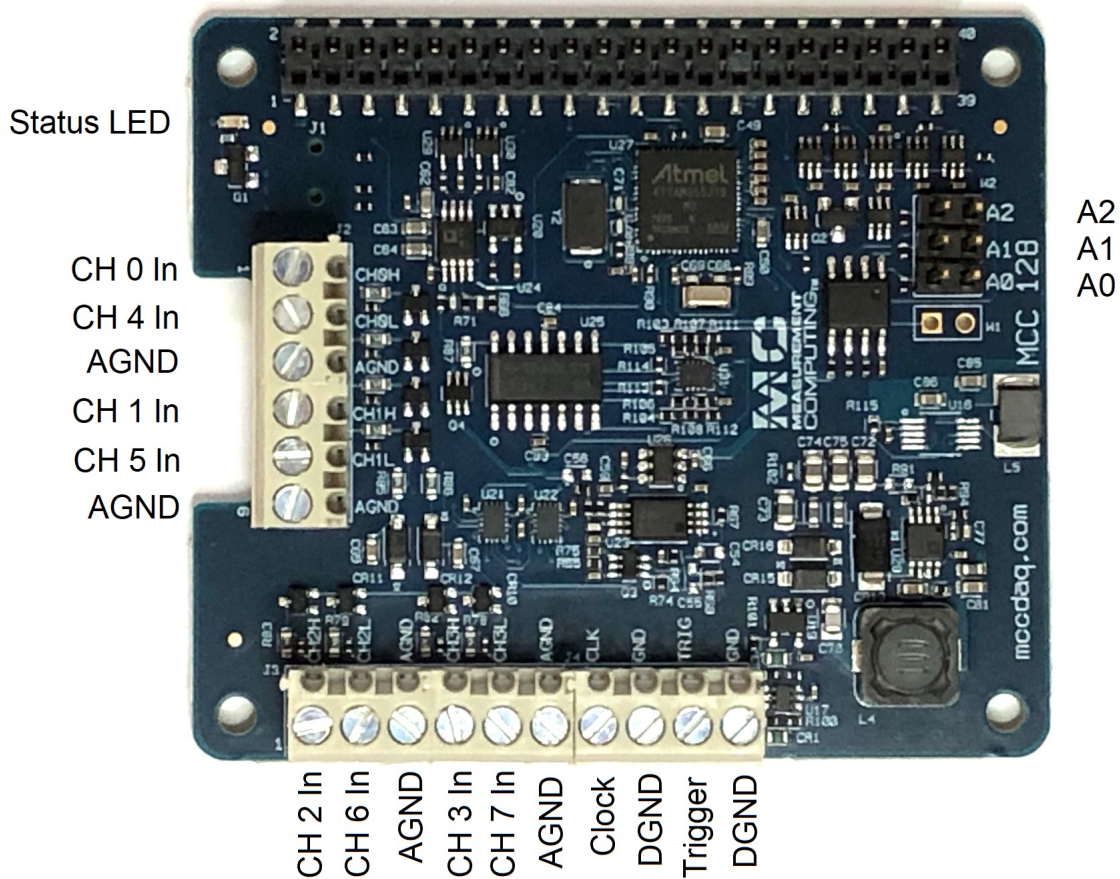

1.3.2 Differential Input Configuration

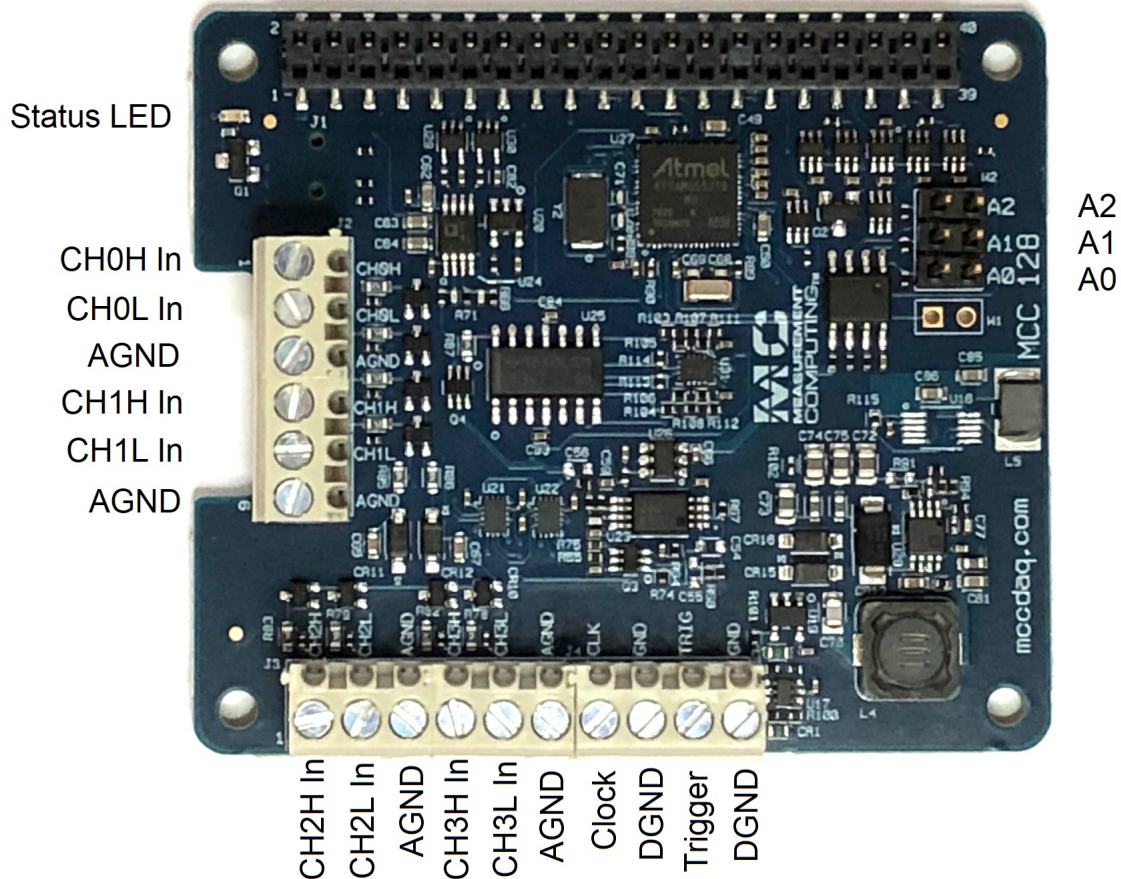

1.3.3 Board components

1.3.3.1 Screw terminals

- **CH0H/CH0L** to **CH3H/CH3L** (CHx): Analog input terminals.
- **Clock** (CLK): Bidirectional terminal for scan clock input / output. Set the direction with software. Set for input to clock the scans with an external clock signal, or output to use the internal scan clock.
- **Trigger** (TRIG): External digital trigger input terminal. The trigger mode is software configurable for edge or level sensitive, rising or falling edge, high or low level.
- **AGND** (GND): Common ground for the analog input terminals.
- **DGND** (GND): Common ground for the clock and trigger terminals.

1.3.3.2 Address jumpers

- **A0 to A2:** Used to identify each HAT when multiple boards are connected. The first HAT connected to the Raspberry Pi must be at address 0 (no jumper). Install jumpers on each additional connected board to set the desired address. Refer to the *Installing multiple boards* topic for more information about the recommended addressing method.

1.3.3.3 Status LED

The LED turns on when the board is connected to a Raspberry Pi with external power applied and flashes when communicating with the board. The LED may be blinked by the user.

1.3.3.4 Header connector

The board header is used to connect with the Raspberry Pi. Refer to *Installing the DAQ HAT board* for more information about the header connector.

1.3.4 Functional block diagram

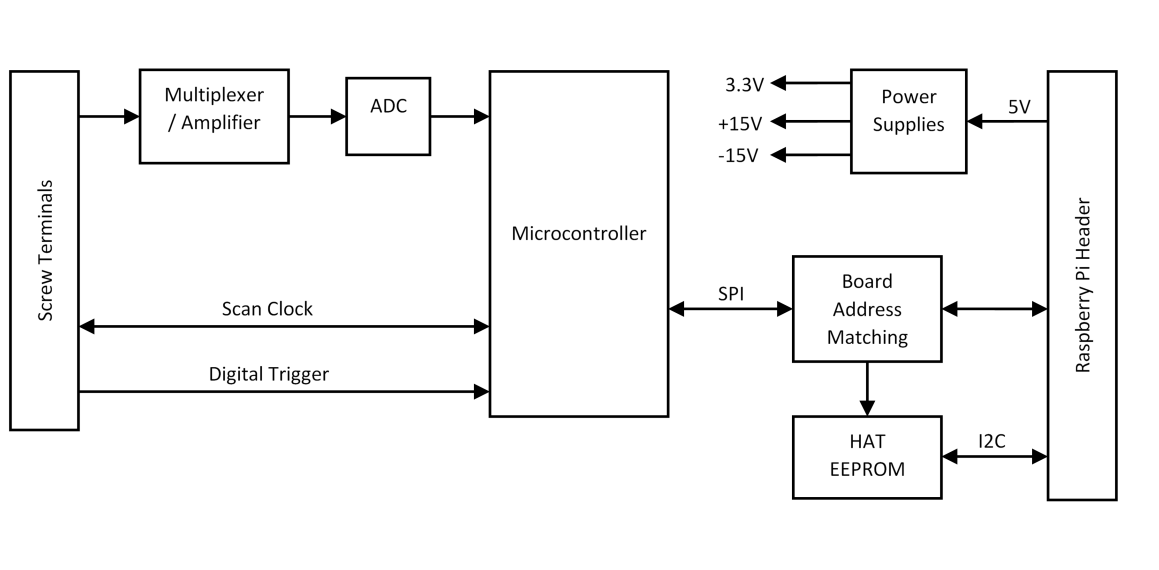

1.3.5 Functional details

1.3.5.1 Scan clock

The clock input / output (terminal CLK) is used to output the internal scan clock or apply an external scan clock to the device. The clock input signal may be a 3.3V or 5V TTL or CMOS logic signal, and the output will be 3.3V LVCMOS. A scan occurs for each rising edge of the clock, acquiring one sample from each of the selected channels in the scan. For example, when scanning channels 0, 1, and 2 the conversion activity will be:

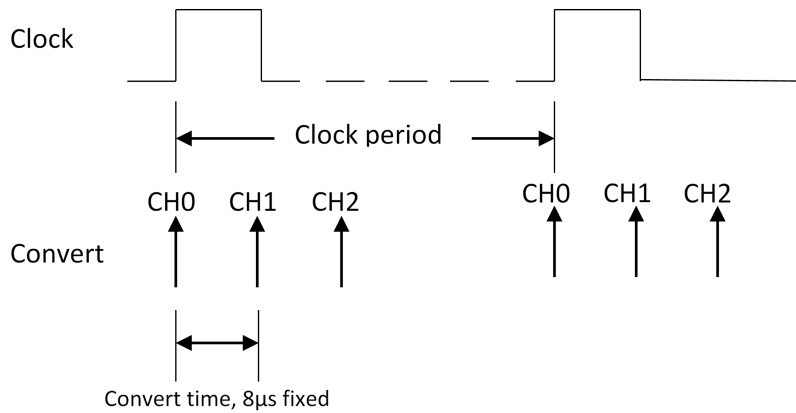

1.3.5.2 Trigger

The trigger input (terminal TRIG) is used to hold off the beginning of an analog input scan until the desired condition is met at the trigger input. The trigger input signal may be a 3.3V or 5V TTL or CMOS logic signal. The input condition may be rising edge, falling edge, high level, or low level.

1.3.6 Firmware updates

Use the firmware update tool to update the firmware on your MCC 128 board(s). The “0” in the example below is the board address. Repeat the command for each MCC 128 address in your board stack. This example demonstrates how to update the firmware on the MCC 128 that is installed at address 0:

```
mcc128_firmware_update 0 ~/daqhats/tools/MCC_128.fw
```

1.3.7 MCC 128-OEM

An OEM version is available that is designed with (unpopulated) header connectors instead of screw terminals. The board accepts 1x6 and 1x10 0.1" spacing header connectors. The MCC 128-OEM is functionally equivalent to the standard version. Refer to the Electrical Specifications for connector information.

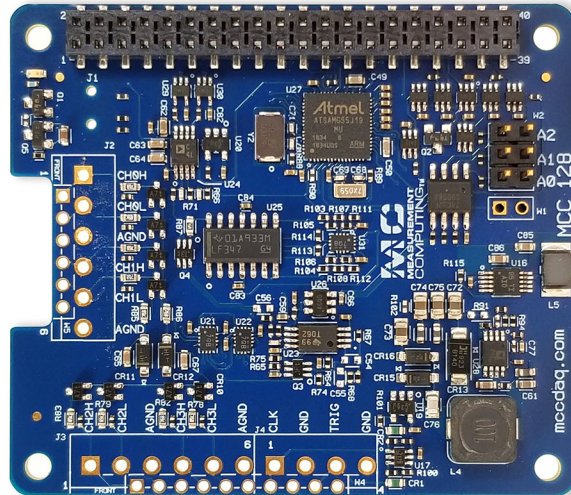

1.3.8 Specifications

All specifications are subject to change without notice.

Typical for 25 °C unless otherwise specified.

Specifications in *italic text* are guaranteed by design.

Analog input

Table 1. Analog input specifications

Parameter	Condition	Specification
A/D converter type		Successive approximation
ADC resolution		16 bits
Input modes		Single ended (CHx – AGND) Differential (CHxH – CHxL)
Number of channels		8 single-ended or 4 differential; software-selectable
Input voltage ranges		$\pm 10\text{ V}$, $\pm 5\text{ V}$, $\pm 2\text{ V}$, $\pm 1\text{ V}$
<i>Absolute maximum input voltage</i>	<i>CHx relative to AGND</i>	$\pm 30\text{ V max (power on)}$ $\pm 20\text{ V max (power off)}$
<i>Input impedance</i>		$> 1\text{ G}\Omega$
<i>Input bias current</i>		$\pm 200\text{ pA, typ}$
INL		$\pm 1.8\text{ LSB}$
DNL		16 bits no missing codes
CMRR	DC to 5 kHz	$\pm 10\text{ V range: } 56\text{ dB}$ $\pm 5\text{ V range: } 57\text{ dB}$ $\pm 2\text{ V range: } 61\text{ dB}$ $\pm 1\text{ V range: } 65\text{ dB}$
Input bandwidth	Small signal (-3 dB)	220 kHz
Maximum working voltage	Input range relative to AGND	$\pm 10.1\text{ V max}$
Crosstalk	Adjacent channels, DC to 10 kHz	-70 dB
Input coupling		DC
Recommended warm up time		1-minute min
Sampling rate, hardware paced	Internal scan clock	1 S/s to 100 kS/s, software-selectable
	External scan clock	100 kS/s max
Sampling mode		One A/D conversion for each configured channel per clock
Conversion time	Per channel	9.8 μs
Scan clock source		<ul style="list-style-type: none"> ■ Internal scan clock ■ External scan clock input on terminal CLK
Channel queue		Up to eight unique, ascending channels in a single range and mode
Throughput, Raspberry Pi® 2 / 3 / 4	Single board	100 kS/s max
	Multiple boards	Up to 320 kS/s aggregate (Note 1)
Throughput, Raspberry Pi A+ / B+	Single board	Up to 100 kS/s (Note 1)
	Multiple boards	Up to 100 kS/s aggregate (Note 1)

Note 1: Depends on the load on the Raspberry Pi processor. The highest throughput may be achieved by using a Raspberry Pi 3 B+. Accuracy

Analog input DC voltage measurement accuracy

Table 2. Absolute accuracy

Range	At full scale (typical at 25 °C)	At full scale (maximum over temperature)
SE ±10 V	±6 mV	±34 mV
SE ±5 V	±3 mV	±17 mV
SE ±2 V	±1.2 mV	±7 mV
SE ±1 V	±600 μV	±3.4 mV
Diff. ±10 V	±14 mV	±42 mV
Diff. ±5 V	±6.5 mV	±21 mV
Diff. ±2 V	±2.1 mV	±8 mV
Diff. ±1 V	±900 μV	±3.7 mV

Noise performance

For the peak to peak noise distribution test, the input channel is in single-ended mode connected to AGND at the input terminal block, and 100,000 samples are acquired at the maximum throughput. The performance is the same for single-ended and differential mode.

Table 3. Noise performance specifications

Range	Vrms
±10 V	350 μV
±5 V	220 μV
±2 V	150 μV
±1 V	100 μV

External digital trigger

Table 4. External digital trigger specifications

Parameter	Specification
Trigger source	TRIG input
Trigger mode	Software configurable for edge or level sensitive, rising or falling edge, high or low level.
Trigger latency	Internal scan clock: 1 μs max External scan clock: 1 μs + 1 scan clock cycle max
Trigger pulse width	125 ns min
Input type	Schmitt trigger, 100 kΩ pull-down to ground
Input high voltage threshold	1.3 V min
Input low voltage threshold	1.5 V max
Input hysteresis	0.4 V min
Input voltage limits	5.5 V absolute max -0.5 V absolute min 0 V recommended min

External scan clock input/output

Table 5. External scan clock I/O specifications

Parameter	Specification
Terminal name	CLK
Terminal types	Bidirectional, defaults to input when not sampling analog channels
Direction (software selectable)	Output: Outputs internal scan clock, active on rising edge Input: Receives scan clock from external source, active on rising edge
Input clock rate	100 kHz max
Input clock pulse width	400 ns min
Input type	Schmitt trigger, 100 k Ω pull-down to ground
Input high voltage threshold	1.3 V min
Input low voltage threshold	1.5 V max
Input hysteresis	0.4 V min
Input voltage limits	5.5V absolute max -0.5V absolute min 0V recommended min
Output high voltage	3.0 V min (IOH = -100 μ A) 2.4 V min (IOH = -4 mA)
Output low voltage	0.1 V max (IOL = 100 μ A) 0.4 V max (IOL = 4 mA)
Output current	\pm 4 mA max

Memory

Table 6. Memory specifications

Parameter	Specification
Data FIFO	72 K (73,728) analog input samples
Non-volatile memory	4 KB (ID and calibration storage, no user-modifiable memory)

Power

Table 7. Power specifications

Parameter	Conditions	Specification
Supply current, 5V supply	Typical	85 mA
	Maximum	135 mA

Interface specifications

Table 8. Interface specifications

Parameter	Specification
Raspberry Pi TM GPIO pins used	GPIO 8, 9, 10, 11 (SPI interface) ID_SD, ID_SC (ID EEPROM) GPIO 12, 13, 26 (Board address) GPIO 16, 20 (Reset, IRQ)
Data interface type	SPI slave device, CE0 chip select
SPI mode	1
SPI clock rate	18 MHz, max

Environmental

Table 9. Environmental specifications

Parameter	Specification
Operating temperature range	0 °C to 55 °C
Storage temperature range	-40 °C to 85 °C
Humidity	0% to 90% non-condensing

Mechanical

Table 10. Mechanical specifications

Parameter	Specification
Dimensions (L × W × H)	65 × 56.5 × 12 mm (2.56 × 2.22 × 0.47 in.) max

Screw terminal connector

Table 11. Screw terminal connector specifications

Parameter	Specification
Connector type	Screw terminal
Wire gauge range	16 AWG to 30 AWG

Table 12. Differential mode terminal pinout

Connector J2		
Pin	Signal name	Pin description
1	CH0H	Analog input 0 Hi
2	CH0L	Analog input 0 Lo
3	AGND	Analog ground
4	CH1H	Analog input 1 Hi
5	CH1L	Analog input 1 Lo
6	AGND	Analog ground
Connector J3		
Pin	Signal name	Pin description
7	CH2H	Analog input 2 Hi
8	CH2L	Analog input 2 Lo
9	AGND	Analog ground
10	CH3H	Analog input 3 Hi
11	CH3L	Analog input 3 Lo
12	AGND	Analog ground
13	CLK	Scan clock input / output
14	GND	Digital ground
15	TRIG	Digital trigger input
16	GND	Digital ground

Table 13. Single-ended mode terminal pinout

Connector J2		
Pin	Signal name	Pin description
1	CH0	Analog input 0
2	CH4	Analog input 4
3	AGND	Analog ground
4	CH1	Analog input 2
5	CH5	Analog input 3
6	AGND	Analog ground
Connector J3		
Pin	Signal name	Pin description
7	CH2	Analog input 4
8	CH6	Analog input 5
9	AGND	Analog ground
10	CH3	Analog input 6
11	CH7	Analog input 7
12	AGND	Analog ground
13	CLK	Scan clock input / output
14	GND	Digital ground
15	TRIG	Digital trigger input
16	GND	Digital ground

1.4 MCC 134

The MCC 134 is a 4-channel thermocouple input board with the following features:

- 24-bit A/D converter
- Onboard sensor for cold junction compensation
- Linearization for J, K, R, S, T, N, E, B type thermocouples
- Open thermocouple detection
- Thermocouple inputs are electrically isolated from the Raspberry Pi for use in harsh environments

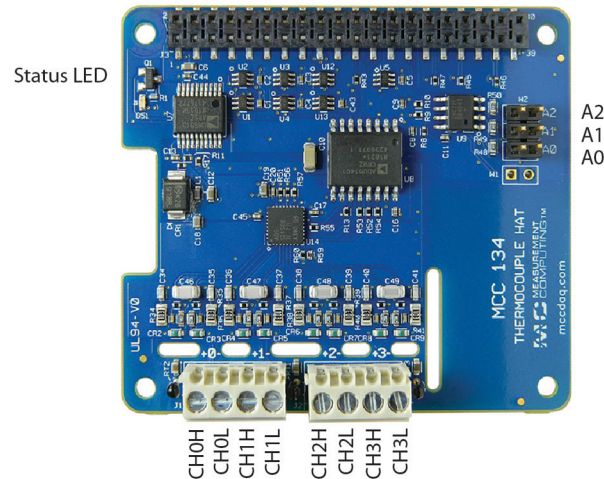

1.4.1 Board components

1.4.1.1 Screw terminals

- **CH0H/CH0L** to **CH3H/CH3L** (+x-): Differential thermocouple input terminals.

1.4.1.2 Address jumpers

- **A0** to **A2**: Used to identify each HAT when multiple boards are connected. The first HAT connected to the Raspberry Pi must be at address 0 (no jumper). Install jumpers on each additional connected board to set the desired address. Refer to the *Installing multiple boards* topic for more information about the recommended addressing method.

1.4.1.3 Status LED

The LED turns on when the board is connected to a Raspberry Pi with external power applied.

1.4.1.4 Header connector

The board header is used to connect with the Raspberry Pi. Refer to *Installing the DAQ HAT board* for more information about the header connector.

1.4.2 Functional block diagram

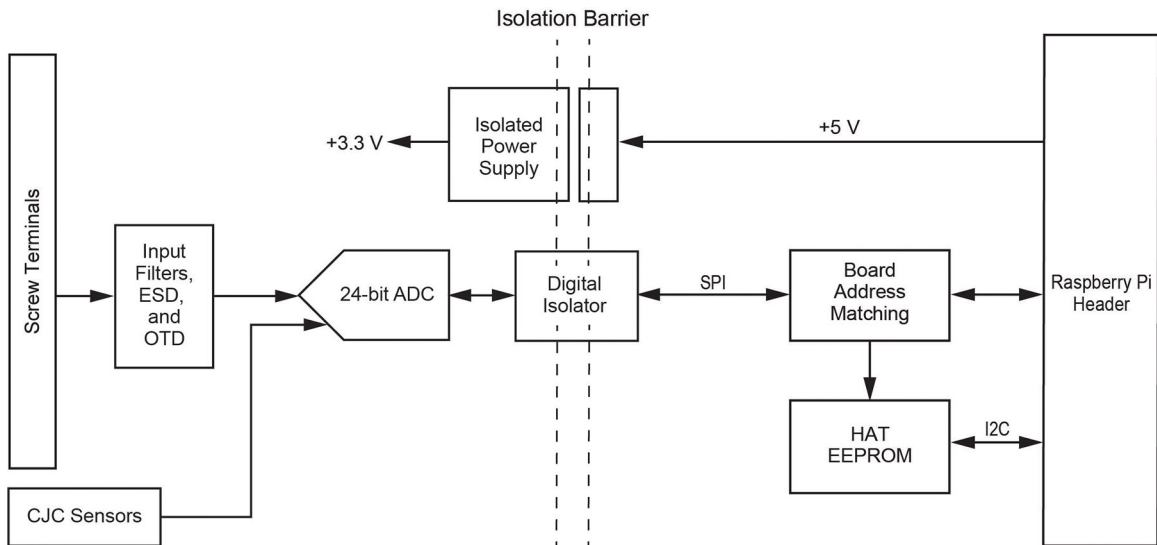

1.4.3 Functional details

1.4.3.1 Best practices for accurate thermocouple measurements

The MCC 134 should achieve results within the maximum thermocouple accuracy specifications when operating within the documented environmental conditions. Operating in conditions with excessive temperature transients or airflow may affect results. In most cases, the MCC 134 will achieve the typical specifications. To achieve the most accurate thermocouple readings, MCC recommends the following practices:

- *Reduce the load on the Raspberry Pi processor.* Running a program that fully loads all 4 cores on the Raspberry Pi processor can raise the temperature of the processor above 70 °C. Running a program that only loads 1 core will operate approximately 20 °C cooler.
- *Minimize environmental temperature variations.* Place the MCC 134 away from heat or cooling sources that cycle on and off. Sudden environmental changes may lead to increased errors.
- *Provide a steady airflow, such as from a fan.* A steady airflow can dissipate heat and reduce errors.
- *When configuring multiple MCC DAQ Hats in a stack, position the MCC 134 farthest from the Raspberry Pi board.* Since the Raspberry Pi is a significant heat source, placing the MCC 134 farthest from the Pi will increase accuracy.

For additional information, refer to the [Measuring Thermocouples with Raspberry Pi](#) and the [MCC 134 Tech Tip](#).

1.4.4 Specifications

All specifications are subject to change without notice.
 Typical for 25 °C unless otherwise specified.
 Specifications in *italic text* are guaranteed by design.

Thermocouple input

Table 1. Thermocouple input specifications

Parameter	Condition	Specification
A/D converter		Delta-Sigma
ADC resolution		24 bits
Number of channels		4
<i>Input isolation</i>	<i>Between input and Raspberry Pi ground</i>	<i>500 Vpk withstand max</i>
<i>Differential input voltage range</i>		<i>±78.125 mV</i>
<i>Common mode voltage range</i>	<i>Between any CHx+ or – input and any other input</i>	<i>0.8 V max</i>
<i>Absolute maximum input voltage</i>	<i>Between any two TCx inputs</i>	<i>±25 V (power on) ±25 V (power off)</i>
<i>Differential input impedance</i>		<i>40 MΩ</i>
<i>Input current</i>		<i>83 nA</i>
<i>Common mode rejection</i>	<i>f_{IN} = 50 Hz or 60 Hz</i>	<i>93 dB</i>
Update interval		1 second min
Open thermocouple detection response time		2 seconds
Recommended warm-up time		15 minutes min
Calibration method		Factory

Compatible thermocouples

Table 2. Compatible sensor type specifications

Parameter	Specification
Thermocouple type	J: –210 °C to 1200 °C
	K: –270 °C to 1372 °C
	R: –50 °C to 1768 °C
	S: –50 °C to 1768 °C
	T: –270 °C to 400 °C
	N: –270 °C to 1300 °C
	E: –270 °C to 1000 °C
	B: 50 °C to 1820 °C

Accuracy

Thermocouple measurement accuracy

Thermocouple accuracy specifications, including typical CJC measurement error. All specifications are (\pm).

- Note 1:** Thermocouple measurement accuracy specifications include polynomial linearization, cold-junction compensation error, and system noise. Accuracies shown do not include inherent thermocouple error or large temperature gradients across the board. Contact your thermocouple supplier for details on the inherent thermocouple accuracy error. The accuracy specifications assume the device has been warmed up for the recommended 15 minutes.
- Note 2:** To avoid excessive cold-junction compensation errors, operate the device in a stable temperature environment and away from heat sources that could cause temperature gradients across the board. Refer to the documentation for ways to decrease this error.
- Note 3:** When thermocouples are attached to conductive surfaces, the voltage differential between multiple thermocouples must remain within ± 0.8 V. For best results MCC recommends using electrically insulated thermocouples when possible.

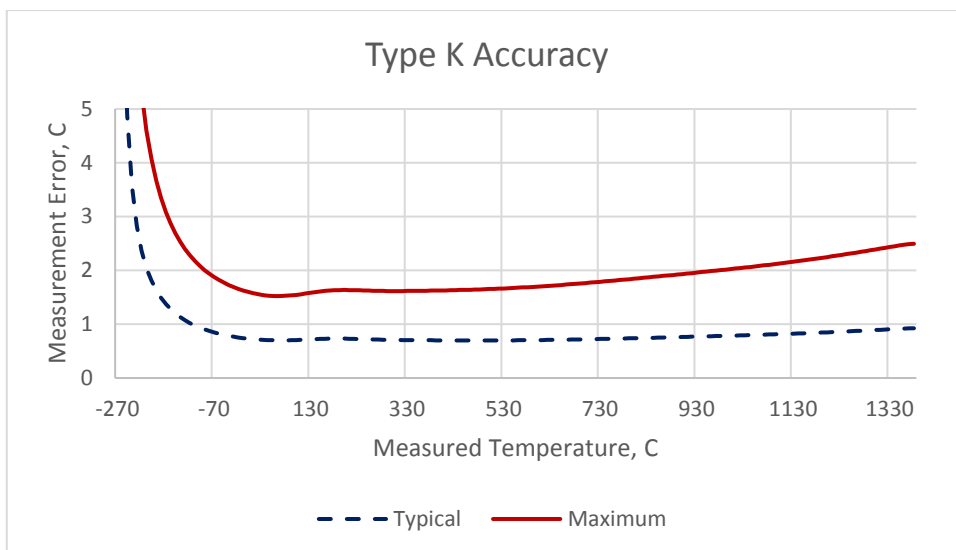
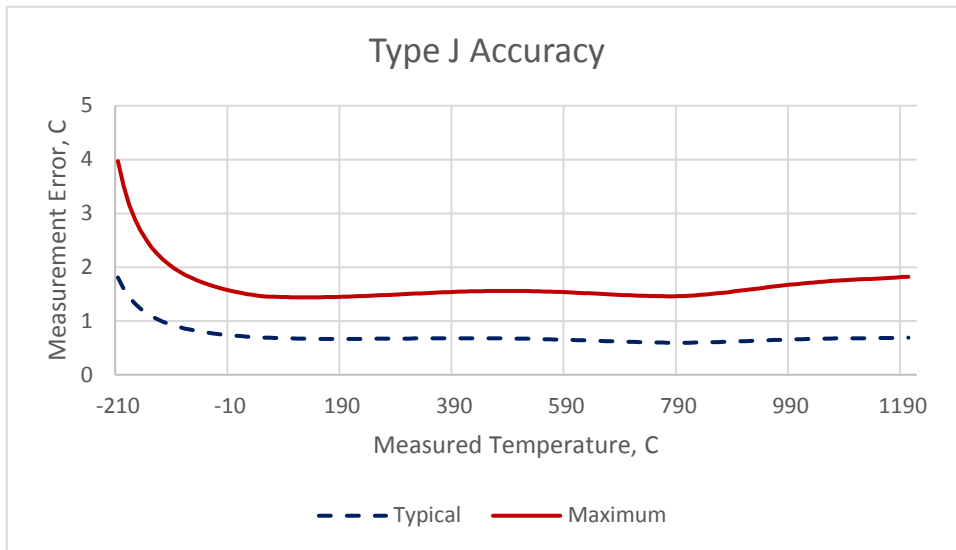

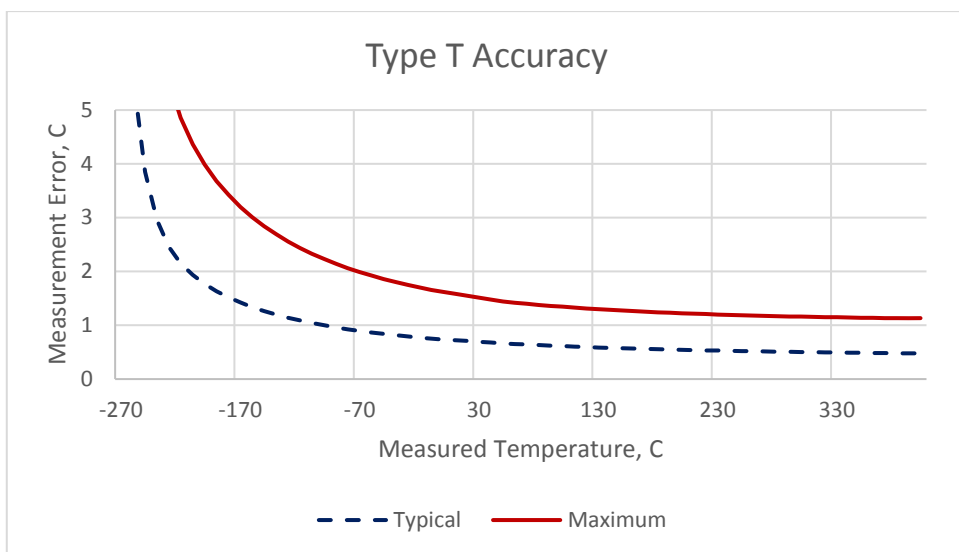
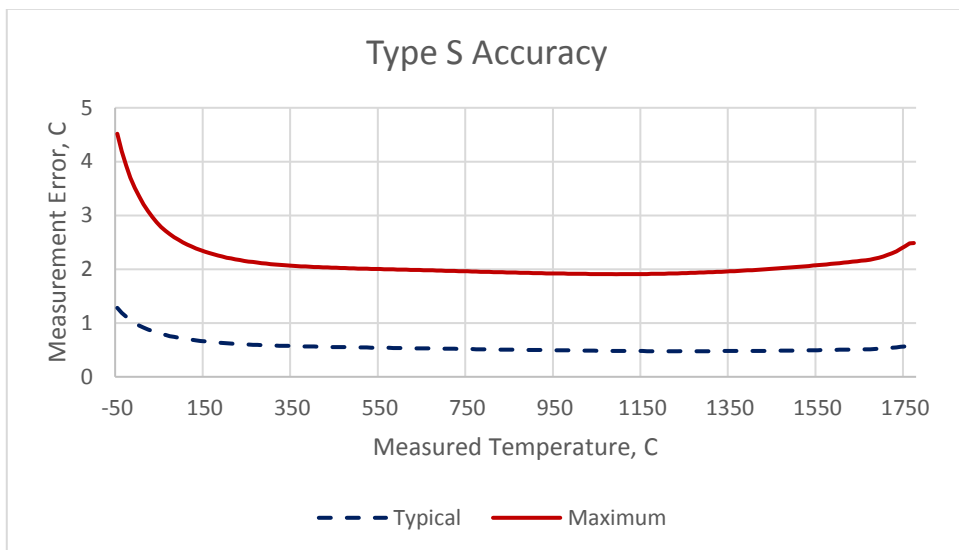
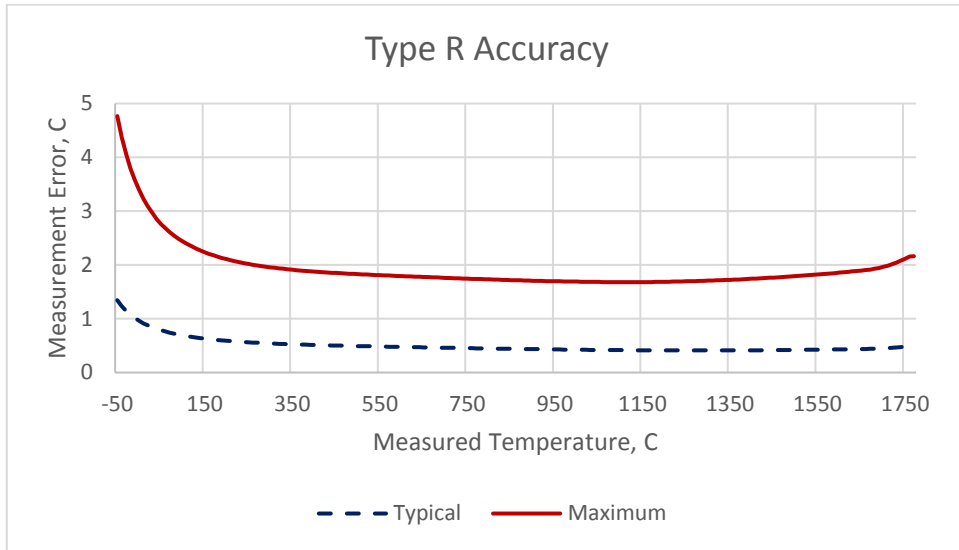

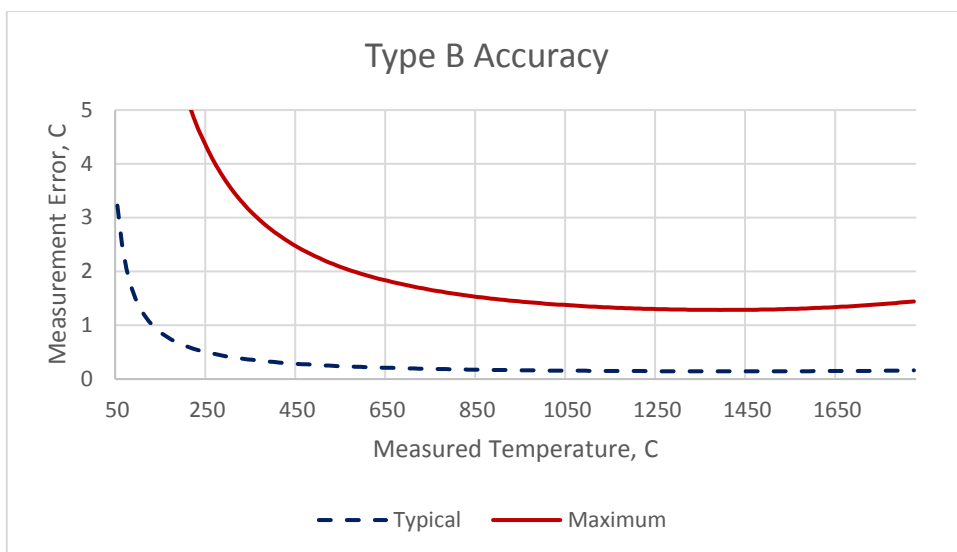
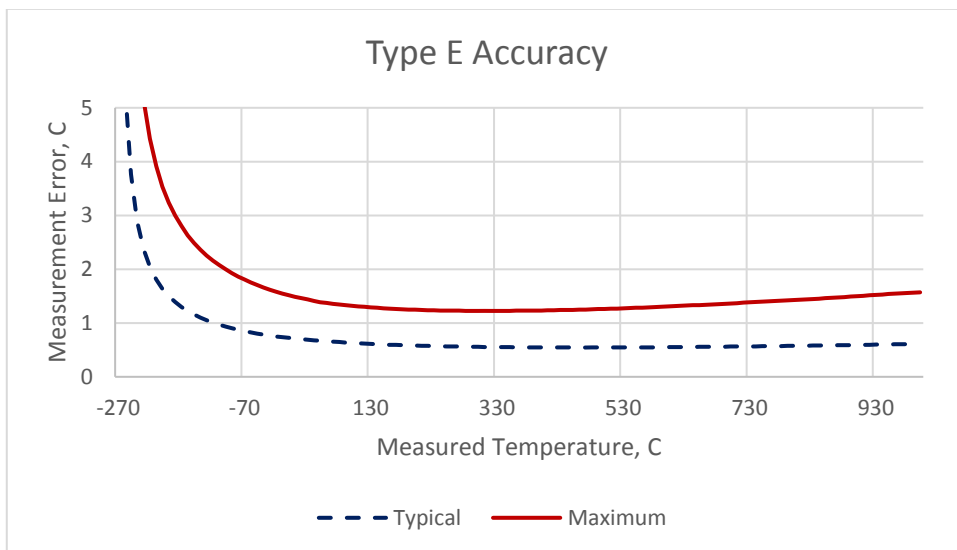
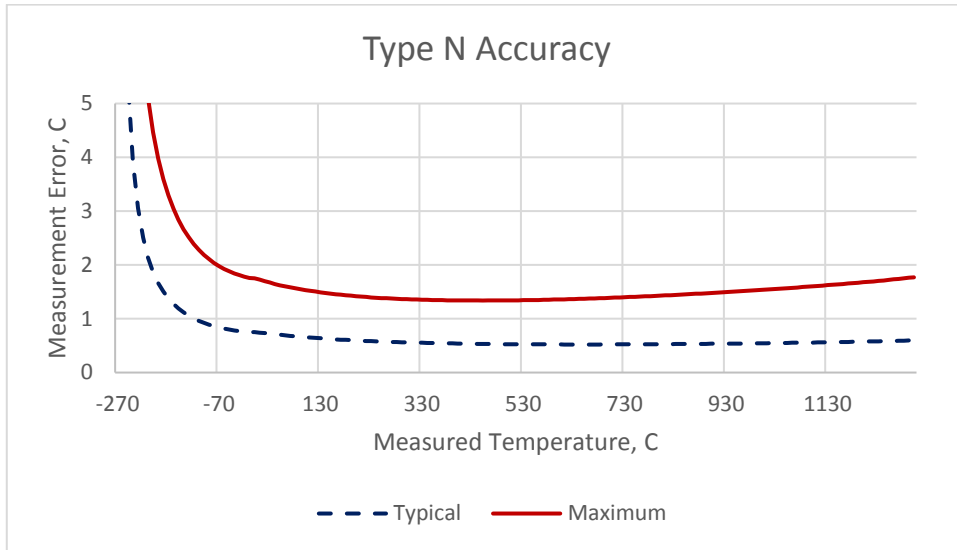

Memory

Table 3. Memory specifications

Parameter	Specification
Non-volatile memory	4 KB (ID and calibration storage, no user-modifiable memory)

Power

Table 4. Power specifications

Parameter	Conditions	Specification
Supply current, 5V supply	Typical	16 mA
	Maximum	24 mA
Supply current, 3.3V supply	Typical	1 mA
	Maximum	5 mA

Interface

Table 5. Interface specifications

Parameter	Specification
Raspberry Pi™ GPIO pins used	GPIO 8, GPIO 9, GPIO 10, GPIO 11 (SPI interface) ID_SD, ID_SC (ID EEPROM) GPIO 12, GPIO 13, GPIO 26, (Board address)
Data interface type	SPI slave device, CE0 chip select
SPI mode	1
SPI clock rate	2 MHz, max

Environmental

Table 6. Environmental specifications

Parameter	Specification
Operating temperature range	0 °C to 55 °C
Storage temperature range	-40 °C to 85 °C
Humidity	0 °C to 90% non-condensing

Mechanical

Table 7. Mechanical specifications

Parameter	Specification
Dimensions (L × W × H)	65 × 56.5 × 12 mm (2.56 × 2.22 × 0.47 in.) max

Screw terminal connector

Table 8. Screw terminal connector specifications

Parameter	Specification
Connector type	Screw terminal
Wire gauge range	16 AWG to 30 AWG

Table 9. Screw terminal pinout

Pin	Signal Name	Pin Description
1	CH0H	CH0 sensor input (+)
2	CH0L	CH0 sensor input (-)
3	CH1H	CH1 sensor input (+)
4	CH1L	CH1 sensor input (-)
5	CH2H	CH2 sensor input (+)
6	CH2L	CH2 sensor input (-)
7	CH3H	CH3 sensor input (+)
8	CH3L	CH3 sensor input (-)

1.5 MCC 152

The MCC 152 is an analog output / digital I/O board with the following features:

- 2 analog outputs
 - 12-bit D/A converter
 - 0 - 5 V outputs
 - 5 mA output drive, sourcing
 - Simultaneous update capability
- 8 digital I/O
 - 5 V / 3.3 V supply voltage, jumper-selectable
 - Bit-configurable for input (power on default) or output
 - Outputs may be set to push-pull or open-drain (port-configurable)
 - Programmable pull-up/pull-down resistors (disconnected on outputs when set to open-drain)
 - 10 mA source/25 mA sink per output
 - Interrupt on input state change

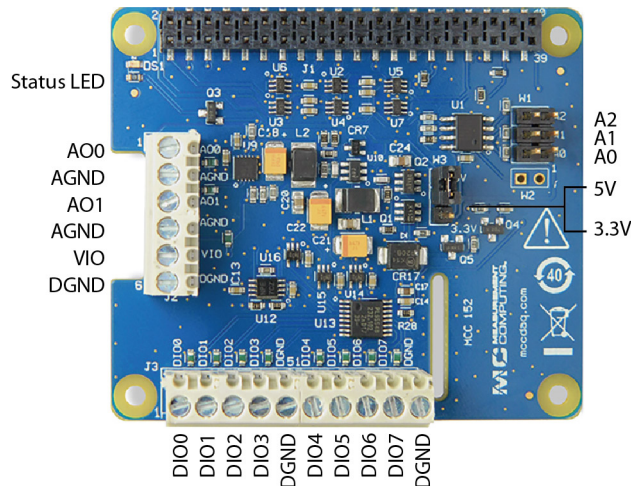

1.5.1 Board components

1.5.1.1 Screw terminals

- **AO0** to **AO1** (AOx): Analog output terminals.
- **DIO0** to **DIO7** (DIOx): Digital input/output terminals.
- **VIO** (VIO): Digital I/O supply voltage (5 V or 3.3 V, selectable with jumper W3.)
- **AGND** (AGND): Common ground for the analog output terminals.
- **DGND** (DGND): Common ground for the digital I/O terminals.

1.5.1.2 Address jumpers

- **A0 to A2:** Used to identify each DAQ HAT when multiple boards are connected. The first DAQ HAT connected to the Raspberry Pi must be at address 0 (no jumper). Install jumpers on each additional connected board to set the desired address. Refer to the *Installing multiple boards* topic for more information about the recommended addressing method.

1.5.1.3 DIO Power jumper (W3)

- **5V and 3.3V:** Selects the DIO voltage; the factory default is 5 V. Refer to *Mixing 3.3V and 5V digital inputs* for more information about the DIO supply voltage.

1.5.1.4 Status LED

The LED turns on when the board is connected to a Raspberry Pi with external power applied.

1.5.1.5 Header connector

The board header is used to connect with the Raspberry Pi. Refer to *Installing the DAQ HAT board* for more information about the header connector.

1.5.2 Functional block diagram

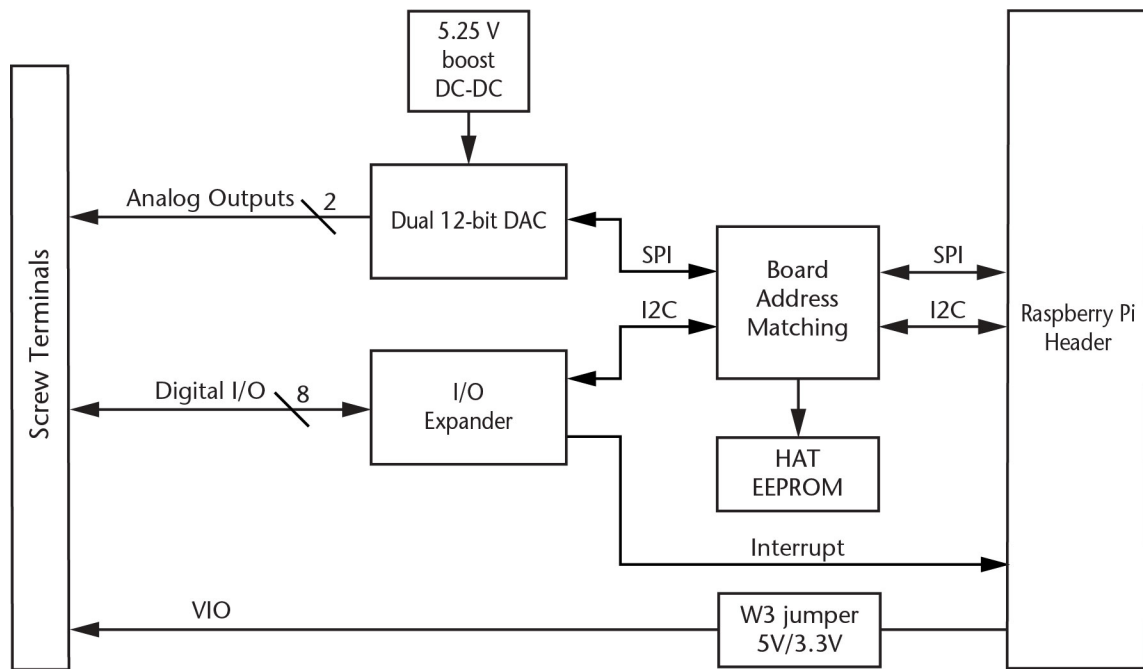

1.5.3 Functional details

1.5.3.1 Mixing 3.3V and 5V digital inputs

The MCC 152 digital inputs are tolerant of 5V signals when the DIO is set to 3.3V operation with jumper W3. However, current can flow into the MCC 152 from the 5V signal, so the user must limit this current to avoid raising the voltage of the digital power supply rail (VIO) and possibly damaging components. MCC recommends using a series resistor of 700 ohms or larger.

Example:

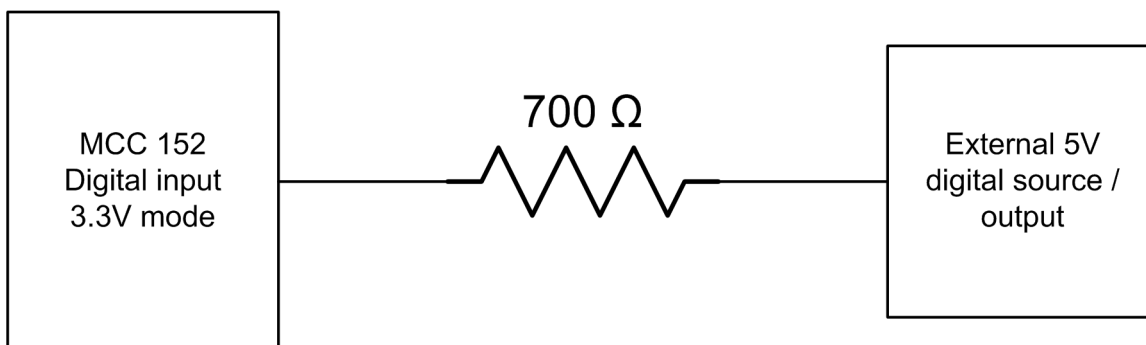

1.5.4 Specifications

All specifications are subject to change without notice.

Typical for 25 °C unless otherwise specified.

Specifications in *italic text* are guaranteed by design.

Analog output

Table 1. Analog output specifications

Parameter	Condition	Specification
Resolution		12 bits, 1 in 4,096
<i>Output range</i>		<i>0 V to 5.0 V</i>
Number of channels		2
Write time		12 μ s, typ
Power on and reset voltage	Initializes to 000h code	0 V, \pm 10 mV
Output drive	Each D/A OUT	5 mA, sourcing
Slew rate		0.8 V/ μ s typ
Differential nonlinearity		\pm 0.25 LSB max
Zero-scale error (Note 1)	000h code	+2 mV typ +10 mV max
Full-scale error	FFFh code	-0.1 % of FSR typ \pm 1 % of FSR max
Offset error		\pm 1 mV typ \pm 10 mV max
Gain error		\pm 1.5 % of FSR max

Note 1: Zero-scale error may result in a "dead-band" digital input code region. In this case, changes in requested output voltage may not produce a corresponding change in the output voltage when the voltage is less than 10 mV. The offset error is tested and specified at 10 mV.

Note 2: Error tested at no load.

Digital input/output

Table 2. Digital I/O specifications

Parameter	Conditions	Specification
Digital input type		CMOS
Number of I/O		8
Configuration		Each bit may be configured as input (power on default) or output
Pull-up configuration		Each bit has a programmable 100 k Ω pull resistor (50 to 150 k Ω range) that may be programmed as pull-up (power on default), pull-down, or disabled. The pull-up/down resistors are disabled on outputs when in open-drain mode.
DIO supply voltage (VIO)		5 V or 3.3 V, jumper selectable with jumper W3 (factory default is 5 V.)
Port read time		400 μ s, typ
Port write time		550 μ s, typ
Interrupt functionality		Each bit may be configured to generate an interrupt on change when in input mode.
Input low voltage threshold		0.3 x VIO V max
Input high voltage threshold		0.7 x VIO V min
Input voltage limits	Both 3.3 V and 5 V modes	6.5 V absolute max (Note 3) -0.5 V absolute min

Parameter	Conditions	Specification
Input voltage recommended range	5 V mode	5.5 V max 0 V min
	3.3 V mode	3.8 V max (Note 3) 0 V min
Output type		CMOS, entire port may be configured as push-pull or open-drain
High level output current		10 mA max (Note 4)
Low level output current		25 mA max
Output high voltage	VIO = 3.3 V	2.5 V min (IOH = -10 mA)
	VIO = 5 V	4.0 V min (IOH = -10 mA)
Output low voltage	VIO = 3.3 V	0.25 V max (IOL = 10 mA)
	VIO = 5 V	0.2 V max (IOL = 10 mA)

Note 3: When VIO is 3.3V the input will tolerate voltages up to 6.5V, but the voltage must be current-limited or it will change the VIO voltage due to current flowing into the MCC 152. An external current limiting resistor of 700 Ω or larger is recommended on each input that is higher than 3.3V when the W3 jumper is in the 3.3V position.

Memory

Table 3. Memory specifications

Parameter	Specification
Non-volatile memory	4 KB (ID and serial storage, no user-modifiable memory)

Power

Table 4. Power specifications

Parameter	Conditions	Specification
Supply current, 5 V supply	Typical, 5V DIO selection	15 mA
	Maximum, 5V DIO selection	35 mA (Note 5, Note 6)
	Typical, 3.3V DIO selection	10 mA
	Maximum, 3.3V DIO selection	12 mA (Note 5)
Supply current, 3.3 V supply (Note 4)	Typical, 5V DIO selection	0.01 mA
	Maximum, 5V DIO selection	6 mA
	Typical, 3.3V DIO selection	3.5 mA
	Maximum, 3.3V DIO selection	11 mA (Note 5)

Note 4: The power consumed by all DAQ HATs must be within the capacity of the Raspberry Pi power supply. Extra care must be taken with sourcing 3.3V loads since they are supplied by the regulator on the Raspberry Pi; MCC recommends using the 5V DIO selection when sourcing large load currents such as LEDs.

Note 5: This specification does not include user loading on analog outputs.

Note 6: This specification does not include user loading on digital outputs or the VIO terminal.

Interface specifications

Table 5. Interface specifications

Parameter	Specification
Raspberry Pi GPIO pins used	GPIO 8, GPIO 10, GPIO 11 (SPI interface) GPIO 2, GPIO 3 (I2C interface) ID_SD, ID_SC (ID EEPROM) GPIO 12, GPIO 13, GPIO 26, (Board address) GPIO 21 (Interrupt)
Data interface type	SPI slave device, CE0 chip select (Analog output) I2C slave device (Digital I/O)

Parameter	Specification
SPI mode	1
SPI clock rate	50 MHz, max
I2C address	0x20 to 0x27, depending on board address jumper setting
I2C clock rate	400 kHz, max

Environmental

Table 6. Environmental specifications

Parameter	Specification
Operating temperature range	0 °C to 55 °C
Storage temperature range	-40 °C to 85 °C
Humidity	0% to 90% non-condensing

Mechanical

Table 7. Mechanical specifications

Parameter	Specification
Dimensions (L × W × H)	65 × 56.5 × 12 mm (2.56 × 2.22 × 0.47 in.) max

Screw terminal connector

Table 8. Screw terminal connector specifications

Parameter	Specification
Connector type	Screw terminal
Wire gauge range	16 AWG to 30 AWG

Table 9. Screw terminal pinout

Connector J2		
Pin	Signal name	Pin description
1	AO0	Analog output 0
2	AGND	Analog ground
3	AO1	Analog output 1
4	AGND	Analog ground
5	VIO	Digital supply voltage output (5V or 3.3V, depending on W3)
6	DGND	Digital ground
Connector J3		
Pin	Signal name	Pin description
7	DIO0	Digital I/O 0
8	DIO1	Digital I/O 1
9	DIO2	Digital I/O 2
10	DIO3	Digital I/O 3
11	DGND	Digital ground
12	DIO4	Digital I/O 4
13	DIO5	Digital I/O 5
14	DIO6	Digital I/O 6
15	DIO7	Digital I/O 7
16	DGND	Digital ground

1.6 MCC 172

The MCC 172 is a 2-channel analog voltage input board with the following features:

- Two 24-bit, 51.2 kS/s A/D converters (one per channel)
- ± 5 V AC coupled differential analog inputs
- IEPE sensor support
- 10-32 and screw terminal connectors for the analog inputs
- ADC conversions can be synchronized between multiple boards
- Onboard sample buffers
- Digital trigger input

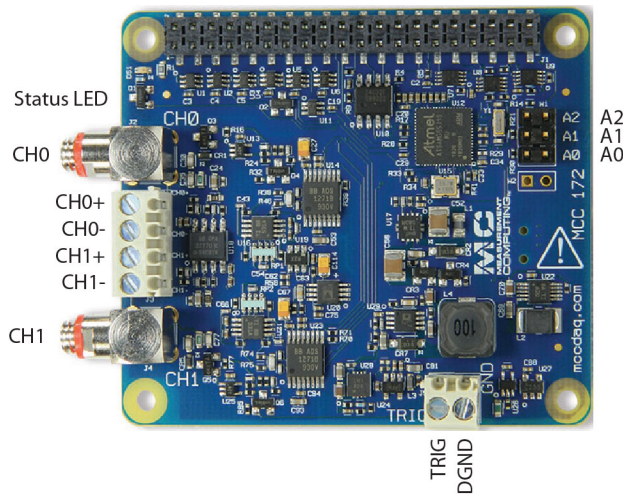

1.6.1 Board components

1.6.1.1 10-32 coaxial connectors

- **CH0** and **CH1** (CH_x): Analog input connectors (do not connect an input source to the 10-32 connectors and screw terminals at the same time).

1.6.1.2 Screw terminals

- **CH0+/CH0-** and **CH1+/CH1-** (CH_x+ / CH_x-): Analog input terminals (do not connect an input source to the 10-32 connectors and screw terminals at the same time).
- **Trigger** (TRIG): External digital trigger input terminal. The trigger mode is software configurable for edge or level sensitive, rising or falling edge, high or low level.
- **DGND** (GND): Digital ground for the trigger terminal.

1.6.1.3 Address jumpers

- **A0 to A2:** Used to identify each HAT when multiple boards are connected. The first HAT connected to the Raspberry Pi must be at address 0 (no jumper). Install jumpers on each additional connected board to set the desired address. Refer to the *Installing multiple boards* topic for more information about the recommended addressing method.

1.6.1.4 Status LED

The LED turns on when the board is connected to a Raspberry Pi with external power applied and flashes when communicating with the board. The LED may be blinked by the user.

1.6.1.5 Header connector

The board header is used to connect with the Raspberry Pi. Refer to *Installing the DAQ HAT board* for more information about the header connector.

1.6.2 Functional block diagram

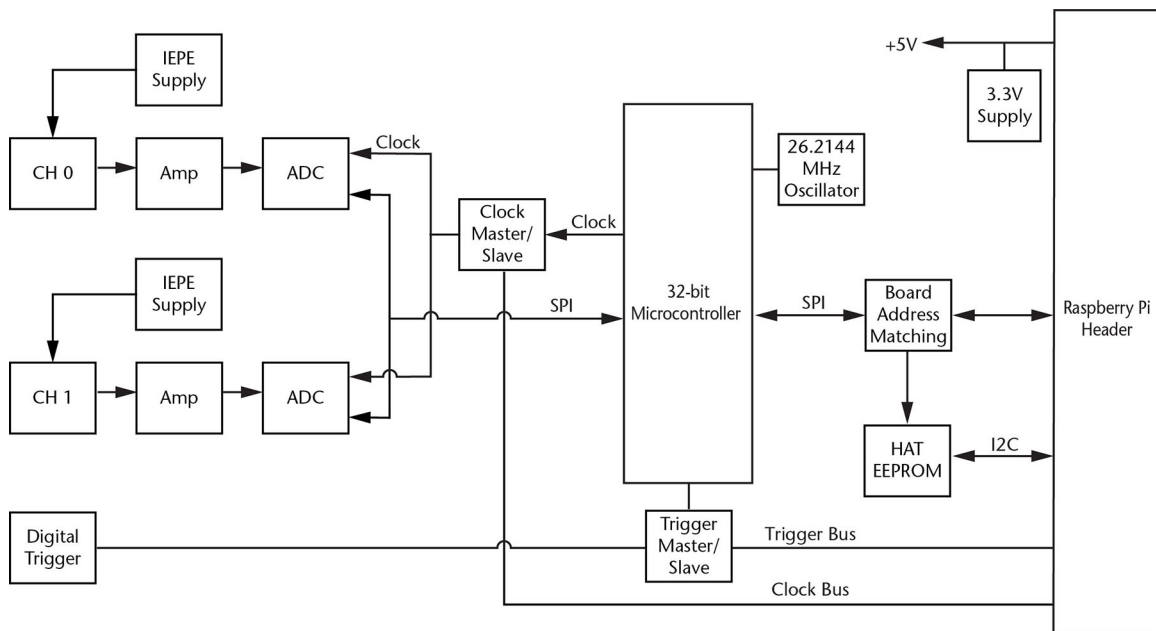

1.6.3 Functional details

1.6.3.1 ADC clock

The ADCs on a board share the same clock and are synchronized to start conversions at the same time for synchronous data. The clock and synchronize signals may also be shared across the Raspberry Pi GPIO header to synchronize multiple MCC 172s. The clock is programmable for various sampling rates between 51.2 kS/s and 200 S/s.

1.6.3.2 Trigger

The trigger input (terminal TRIG) is used to hold off the beginning of an analog input scan until the desired condition is met at the trigger input. The trigger input signal may be a 3.3V or 5V TTL or CMOS logic signal. The input condition may be rising edge, falling edge, high level, or low level. The trigger may also be shared across the Raspberry Pi GPIO header to synchronize multiple MCC 172s.

Due to the nature of the filtering in the A/D converters there is an input delay of 39 samples, so the data coming from the converters at any time is delayed by 39 samples from the current time. This is most noticeable when using a trigger - there will be approximately 39 samples prior to the trigger event in the captured data.

1.6.3.3 Alias Rejection

At low sampling rates, certain high frequency signals (at multiples of 128 * the sampling rate) can fall below the cutoff frequency of the fixed analog anti-aliasing filter and create aliasing in the data. Using transducers with a bandwidth lower than 100 kHz should not affect measurement results. Sampling at 10.24 kHz or higher will also ensure that the anti-aliasing filter suppresses all signals that could alias into the data.

1.6.4 Firmware updates

Use the firmware update tool to update the firmware on your MCC 172 board(s). The “0” in the example below is the board address. Repeat the command for each MCC 172 address in your board stack. This example demonstrates how to update the firmware on the MCC 172 that is installed at address 0:

```
mcc172_firmware_update 0 ~/daqhats/tools/MCC_172.fw
```

1.6.5 Specifications

All specifications are subject to change without notice.

Typical for 25 °C unless otherwise specified.

Specifications in *italic text* are guaranteed by design.

Analog input

Table 1. General analog input specifications

Parameter	Conditions	Specification
Number of channels		2
ADC resolution		24-bit
A/D converter type		Delta sigma
Sampling mode		Simultaneous
Master timebase (f_M)	Frequency	26.2144 MHz
	Accuracy	± 50 ppm max
Master timebase sources		<ul style="list-style-type: none"> ■ Internal clock ■ Shared clock from another MCC 172
Data rates (f_S)		$(f_M / 512) / n, n = 1, 2, \dots, 256$ 51.2 kS/s max 200 S/s min
Input coupling		AC
AC cutoff frequency		-3 dB: 0.78 Hz -0.1 dB: 5.2 Hz max
Input voltage range		± 5 V
Common-mode voltage range	CHx to AGND	± 2 V max
Overvoltage protection	CHx+ to CHx-	± 35 V
	CHx- to ground	± 2.5 V
IEPE compliance voltage		23 V max
IEPE excitation current		4.0 mA min 4.1 mA typ
Input delay	1 kHz to 23 kHz input frequency	$4.5 \mu\text{s} + 39 / f_S$
Channel-to-channel matching	Phase (200 Hz to 23 kHz)	$(f_{in} * 0.022^\circ)$ max
	Gain (20 Hz to 23 kHz)	0.19 dB typ
Passband	Frequency	$0.453 * f_S$
	Flatness (20 Hz to 23 kHz)	52 mdB (pk-to-pk typ)
Phase nonlinearity	$f_S = 51.2$ kS/s 200 Hz to 23 kHz input frequency	$\pm 0.36^\circ$ max
Stopband	Frequency	$0.547 * f_S$
	Rejection	99 dB min
Alias-free bandwidth		$0.453 * f_S$
Alias rejection		100 dB @ 51.2 kS/s
Oversample rate		$128 * f_S$
Crosstalk	1 kHz	-122 dB
SFDR	$f_{in} = 1$ kHz, -60 dBFS	120 dB
Dynamic range	$f_{in} = 1$ kHz, -1 dBFS	100 dB
Input impedance	Differential	202 k Ω
	CHx- (shield) to ground	50 Ω
Throughput	Single board	102.4 kS/s max (51.2 kS/s \times 2 channels)
	Multiple boards	Up to 307.2 kS/s aggregate (Note 1)

Note 1: Dependent on the load on the Raspberry Pi processor and the SPI interface.

Note 2: For best results, connect the signal source and the Raspberry Pi to a common ground. If a floating source is required, connect the MCC 172 to earth ground via the DGND screw terminal to minimize common mode noise.

Accuracy

Analog input AC voltage measurement accuracy

Table 2. AC accuracy components and specifications. All values are (\pm) and apply to calibrated readings

Gain error, max	Offset error, max	Gain temperature coefficient, max	Offset temperature coefficient, max
0.43%	5.10 mV	88 ppm/ $^{\circ}$ C	184 μ V/ $^{\circ}$ C

Noise performance

Table 3. Noise performance specifications

Idle Channel	51.2 kS/s
Noise	33 μ Vrms
Noise density	207 nV/ \sqrt Hz

Total harmonic distortion (THD)

Table 4. Total harmonic distortion specifications

Input Amplitude	1 kHz	8 kHz
-1 dBFS	-93 dB	-91 dB
-10.96 dBFS	-87 dB	-87 dB

External digital trigger

Table 5. External digital trigger specifications

Parameter	Specification
Trigger source	TRIG input
Trigger mode	Software configurable for rising or falling edge, or high or low level
Trigger latency	1 μ s + 1 sample period (1/fs) max
Trigger pulse width	100 ns min
Input type	Schmitt trigger, 100 K pull-down to ground
Input high voltage threshold	1.48 V min
Input low voltage threshold	1.2 V max
Input hysteresis	0.51 V min
Input voltage limits	6.5 V absolute max -0.5 V absolute min 0 V recommended min

Memory

Table 6. Memory specifications

Parameter	Specification
Data FIFO	48 K (49,152) analog input samples
Non-volatile memory	4 KB (ID and calibration storage, no user-modifiable memory)

Power

Table 7. Power specifications

Parameter	Conditions	Specification
Supply current, 5V supply	Typical	100 mA
	Maximum	140 mA

Interface specifications

Table 8. Interface specifications

Parameter	Specification
Raspberry Pi™ GPIO pins used	GPIO 8, 9, 10, 11 (SPI interface) ID_SD, ID_SC (ID EEPROM) GPIO 12, 13, 26, (Board address) GPIO 5, 6, 19, 16, 20 (clock / trigger sharing, reset, IRQ)
Data interface type	SPI slave device, CE0 chip select
SPI mode	1
SPI clock rate	18 MHz, max

Environmental

Table 9. Environmental specifications

Parameter	Specification
Operating temperature range	0 °C to 55 °C
Storage temperature range	−40 °C to 85 °C
Humidity	0% to 90% non-condensing

Mechanical

Table 10. Mechanical specifications

Parameter	Specification
Dimensions (L × W × H)	65 × 56.5 × 12 mm (2.56 × 2.22 × 0.47 in.) max

Signal connectors

Table 11. Analog input signal connector specifications

Parameter	Specification
Connector types	10-32 coaxial / screw terminal (in parallel, only one source may be connected to a channel at a time)
Coaxial input signals	CH0: channel 0 input CH1: channel 1 input
Screw terminal wire gauge range	16 AWG to 30 AWG

Table 12. Analog input screw terminal pinout

Connector J2		
Pin	Signal name	Pin description
1	CH0+	Channel 0 positive input
2	CH0-	Channel 0 negative input
3	CH1+	Channel 1 positive input
4	CH1-	Channel 1 negative input

Table 13. Trigger input screw terminal pinout

Connector J5		
Pin	Signal name	Pin description
1	TRIG	Digital trigger input
2	GND	Digital ground

INSTALLING THE DAQ HAT BOARD

2.1 Installing a single board

1. Power off the Raspberry Pi.
2. Locate the 4 standoffs. A typical standoff is shown here:



3. Attach the 4 standoffs to the Raspberry Pi by inserting the male threaded portion through the 4 corner holes on the Raspberry Pi from the top and securing them with the included nuts from the bottom.
4. Install the 2x20 receptacle with extended leads (MCC provides a Samtec SSQ-120-03-T-D or equivalent) onto the Raspberry Pi GPIO header by pressing the female portion of the receptacle onto the header pins, being careful not to bend the leads of the receptacle. The 2x20 receptacle looks like:

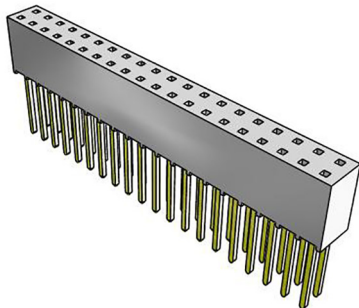

5. **The HAT must be at address 0.** Remove any jumpers from the address header locations A0-A2 on the HAT board.
6. Insert the HAT board onto the leads of the 2x20 receptacle so that the leads go into the holes on the bottom of the HAT board and come out through the 2x20 connector on the top of the HAT board. The 4 mounting holes in the corners of the HAT board must line up with the standoffs. Slide the HAT board down until it rests on the standoffs.
7. Insert the included screws through the mounting holes on the HAT board into the threaded holes in the standoffs and lightly tighten them.

2.2 Installing multiple boards

Follow steps 1-6 in the single board installation procedure for the first HAT board.

1. **Connect all desired field wiring to the installed board - the screw terminals will not be accessible once additional boards are installed above it.**
2. Install the standoffs of the additional board by inserting the male threaded portions through the 4 corner holes of the installed HAT board and threading them into the standoffs below.
3. Install the next 2x20 receptacle with extended leads onto the leads of the previous 2x20 receptacle by pressing the female portion of the new receptacle onto the previous receptacle leads, being careful not to bend the leads of either receptacle.
4. Install the appropriate address jumpers onto address header locations A0-A2 of the new HAT board. The recommended addressing method is to have the addresses increment from 0 as the boards are installed, i.e. 0, 1, 2, and so forth. **There must always be a board at address 0.** The jumpers are installed in this manner (install jumpers where “Y” appears):

Address	A0	A1	A2	Jumper Setting
0				A2
				A1
				A0
1	Y			A2
				A1
				A0
2		Y		A2
				A1
				A0
3	Y	Y		A2
				A1
				A0
4			Y	A2
				A1
				A0
5	Y		Y	A2
				A1
				A0
6		Y	Y	A2
				A1
				A0
7	Y	Y	Y	A2
				A1
				A0

5. Insert the new HAT board onto the leads of the 2x20 receptacle so that the leads go into the holes on the bottom

of the HAT board and come out through the 2x20 connector on the top of the HAT board. The 4 mounting holes in the corners of the HAT board must line up with the standoffs. Slide the HAT board down until it rests on the standoffs.

6. Repeat steps 1-5 for each board to be added.
7. Insert the included screws through the mounting holes on the top HAT board into the threaded holes in the standoffs and lightly tighten them.

INSTALLING AND USING THE LIBRARY

The project is hosted at <https://github.com/mccdaq/daqhats>.

3.1 Installation

1. Power off the Raspberry Pi then attach one or more HAT boards (see *Installing the DAQ HAT board*).
2. Power on the Pi and log in. Open a terminal window if using the graphical interface.
3. Update your package list:

```
sudo apt update
```

4. **Optional:** Update your installed packages and reboot:

```
sudo apt full-upgrade
sudo reboot
```

5. Install git (if not installed):

```
sudo apt install git
```

6. Download this package to your user folder with git:

```
cd ~
git clone https://github.com/mccdaq/daqhats.git
```

7. Build and install the shared library and tools. The installer will detect the HAT board EEPROMs and save the contents if needed:

```
cd ~/daqhats
sudo ./install.sh
```

8. To use the daqhats library with Python install the python library. It may be installed system-wide with:

```
sudo pip install daqhats
```

Recent versions of Python discourage system-wide installation, so you may have to append `--break-system-packages`. To install in a virtual environment (venv), create the venv and install the package (replace `<path_to_venv>` with the desired location of the venv):

```
python -m venv <path_to_venv>
<path_to_venv>/bin/pip install daqhats
```

Note: If you encounter any errors during steps 5 - 7 then `uninstall` the `daqhats` library (if installed), go back to step 4, update your installed packages and reboot, then repeat steps 5 - 7.

if `ioctl` errors are seen when running on a Raspberry Pi 5, update the kernel with:

```
sudo rpi-update
```

You can now run the example programs under `~/daqhats/examples` and create your own programs.

If you are using the Raspberry Pi OS desktop interface, the DAQ HAT Manager utility will be available under the Accessories start menu. This utility will allow you to list the detected DAQ HATs, update the EEPROM files if you change your board stack, and launch control applications for each DAQ HAT to perform simple operations. The code for these programs is in the `daqhats/tools/applications` directory.

You may display a list of the detected boards at any time with the DAQ HAT Manager or the command:

```
daqhats_list_boards
```

If you change your board stackup and have more than one HAT board attached you must update the saved EEPROM images for the library to have the correct board information. You can use the DAQ HAT Manager or the command:

```
sudo daqhats_read_eeproms
```

To display the installed `daqhats` version use:

```
daqhats_version
```

To uninstall the package use:

```
cd ~/daqhats
sudo ./uninstall.sh
```

3.2 Firmware Updates

3.2.1 MCC 118

Use the firmware update tool to update the firmware on your MCC 118 board(s). The “0” in the example below is the board address. Repeat the command for each MCC 118 address in your board stack. This example demonstrates how to update the firmware on the MCC 118 that is installed at address 0:

```
mcc118_firmware_update 0 ~/daqhats/tools/MCC_118.hex
```

3.3 Creating a C program

- The `daqhats` headers are installed in `/usr/local/include/daqhats`. Add the compiler option `-I/usr/local/include` in order to find the header files when compiling, and the include line `#include <daqhats/daqhats.h>` to your source code.
- The shared library, `libdaqhats.so`, is installed in `/usr/local/lib`. Add the linker option `-ldaqhats` to include this library.
- Study the example programs, example makefile, and library documentation for more information.

3.4 Creating a Python program

- The Python package is named *daqhats*. Use it in your code with `import daqhats`.
- Study the example programs and library documentation for more information.

C LIBRARY REFERENCE

The C library is organized as a global function for listing the DAQ HAT boards attached to your system, and board-specific functions to provide full functionality for each type of board. The library may be used with C and C++.

4.1 Global functions and data

4.1.1 Functions

Function	Description
<code>hat_list()</code>	Return a list of detected DAQ HAT boards.
<code>hat_error_message()</code>	Return a text description for a DAQ HAT result.
<code>hat_wait_for_interrupt()</code>	Wait for an interrupt to occur.
<code>hat_interrupt_state()</code>	Read the current interrupt status.
<code>hat_interrupt_callback_enable()</code>	Enable an interrupt callback function.
<code>hat_interrupt_callback_disable()</code>	Disable interrupt callback function.

int **hat_list**(uint16_t filter_id, struct *HatInfo* *list)

Return a list of detected DAQ HAT boards.

It creates the list from the DAQ HAT EEPROM files that are currently on the system. In the case of a single DAQ HAT at address 0 this information is automatically provided by the OS. However, when you have a stack of multiple boards you must extract the EEPROM images using the **daqhats_read_eeproms** tool.

Example usage:

```
int count = hat_list(HAT_ID_ANY, NULL);

if (count > 0)
{
    struct HatInfo* list = (struct HatInfo*)malloc(count *
        sizeof(struct HatInfo));
    hat_list(HAT_ID_ANY, list);

    // perform actions with list

    free(list);
}
```

Parameters

- **filter_id** – An optional *ID* filter to only return boards with a specific ID. Use *HAT_ID_ANY* to return all boards.
- **list** – A pointer to a user-allocated array of struct *HatInfo*. The function will fill the structures with information about the detected boards. You may have an array of the maximum number of boards (*MAX_NUMBER_HATS*) or call this function while passing NULL for list, which will return the count of boards found, then allocate the correct amount of memory and call this function again with a valid pointer.

Returns

The number of boards found.

const char ***hat_error_message**(int result)

Return a text description for a DAQ HAT result code.

Parameters

- **result** – The *Result code* returned from a DAQ HAT function

Returns

The error message.

int **hat_wait_for_interrupt**(int timeout)

Wait for an interrupt to occur.

It waits for the interrupt signal to become active, with a timeout parameter.

This function only applies when using devices that can generate an interrupt:

- MCC 152

Parameters

- **timeout** – Wait timeout in milliseconds. -1 to wait forever, 0 to return immediately.

Returns

RESULT_TIMEOUT, *RESULT_SUCCESS*, or *RESULT_UNDEFINED*.

int **hat_interrupt_state**(void)

Read the current interrupt status.

It returns the status of the interrupt signal. This signal can be shared by multiple boards so the status of each board that may generate must be read and the interrupt source(s) cleared before the interrupt will become inactive.

This function only applies when using devices that can generate an interrupt:

- MCC 152

Returns

1 if interrupt is active, 0 if inactive.

int **hat_interrupt_callback_enable**(void (*function)(void*), void *user_data)

Enable an interrupt callback function.

Set a function that will be called when a DAQ HAT interrupt occurs. The function must have a void return type and void * argument, such as:

```
void function(void* user_data)
```

The function will be called when the DAQ HAT interrupt signal becomes active, and cannot be called again until the interrupt signal becomes inactive. Active sources become inactive when manually cleared (such as reading the digital I/O inputs or clearing the interrupt enable.) If not latched, an active source also becomes inactive when the value returns to the original value (the value at the source before the interrupt was generated.)

The `user_data` argument can be used for passing a reference to anything needed by the callback function. It will be passed to the callback function when the interrupt occurs. Set it to NULL if not needed.

There may only be one callback function at a time; if you call this when a function is already set as the callback function then it will be replaced with the new function and the old function will no longer be called if an interrupt occurs.

The callback function may be disabled with `hat_interrupt_callback_disable()`.

This function only applies when using devices that can generate an interrupt:

- MCC 152

Parameters

- **function** – The callback function.
- **user_data** – The data to pass to the callback function.

Returns

RESULT_SUCCESS or *RESULT_UNDEFINED*.

int **hat_interrupt_callback_disable**(void)

Disable interrupt callbacks.

Removes any callback function from the interrupt handler.

Returns

RESULT_SUCCESS or *RESULT_UNDEFINED*.

4.1.2 Data types and definitions

MAX_NUMBER_HATS 8

The maximum number of DAQ HATs that may be connected.

4.1.2.1 HAT IDs

enum **HatIDs**

Known DAQ HAT IDs.

Values:

enumerator **HAT_ID_ANY**

Match any DAQ HAT ID in `hat_list()`.

enumerator **HAT_ID_MCC_118**

MCC 118 ID.

enumerator **HAT_ID_MCC_118_BOOTLOADER**
MCC 118 in firmware update mode ID.

enumerator **HAT_ID_MCC_128**
MCC 128 ID.

enumerator **HAT_ID_MCC_134**
MCC 134 ID.

enumerator **HAT_ID_MCC_152**
MCC 152 ID.

enumerator **HAT_ID_MCC_172**
MCC 172 ID.

4.1.2.2 Result Codes

enum **ResultCode**

Return values from the library functions.

Values:

enumerator **RESULT_SUCCESS**
Success, no errors.

enumerator **RESULT_BAD_PARAMETER**
A parameter passed to the function was incorrect.

enumerator **RESULT_BUSY**
The device is busy.

enumerator **RESULT_TIMEOUT**
There was a timeout accessing a resource.

enumerator **RESULT_LOCK_TIMEOUT**
There was a timeout while obtaining a resource lock.

enumerator **RESULT_INVALID_DEVICE**
The device at the specified address is not the correct type.

enumerator **RESULT_RESOURCE_UNAVAIL**
A needed resource was not available.

enumerator **RESULT_COMMS_FAILURE**
Could not communicate with the device.

enumerator **RESULT_UNDEFINED**

Some other error occurred.

4.1.2.3 HatInfo structure

struct **HatInfo**

Contains information about a specific board.

Public Members

uint8_t **address**

The board address.

uint16_t **id**

The product ID, one of *HatIDs*.

uint16_t **version**

The hardware version.

char **product_name**[256]

The product name.

4.1.2.4 Analog Input / Scan Option Flags

See individual function documentation for detailed usage information.

OPTS_DEFAULT (0x0000)

Default behavior.

OPTS_NOSCALEDATA (0x0001)

Read / write unscaled data.

OPTS_NOCALIBRATEDATA (0x0002)

Read / write uncalibrated data.

OPTS_EXTCLOCK (0x0004)

Use an external clock source.

OPTS_EXTRIGGER (0x0008)

Use an external trigger source.

OPTS_CONTINUOUS (0x0010)

Run until explicitly stopped.

4.1.2.5 Scan Status Flags

STATUS_HW_OVERRUN (0x0001)

A hardware overrun occurred.

STATUS_BUFFER_OVERRUN (0x0002)

A scan buffer overrun occurred.

STATUS_TRIGGERED (0x0004)

The trigger event occurred.

STATUS_RUNNING (0x0008)

The scan is running (actively acquiring data.)

4.1.2.6 Trigger Modes

enum **TriggerMode**

Scan trigger input modes.

Values:

enumerator **TRIG_RISING_EDGE**

Start the scan on a rising edge of TRIG.

enumerator **TRIG_FALLING_EDGE**

Start the scan on a falling edge of TRIG.

enumerator **TRIG_ACTIVE_HIGH**

Start the scan any time TRIG is high.

enumerator **TRIG_ACTIVE_LOW**

Start the scan any time TRIG is low.

4.2 MCC 118 functions and data

4.2.1 Functions

Function	Description
<code>mcc118_open()</code>	Open an MCC 118 for use.
<code>mcc118_is_open()</code>	Check if an MCC 118 is open.
<code>mcc118_close()</code>	Close an MCC 118.
<code>mcc118_info()</code>	Return information about this device type.
<code>mcc118_blink_led()</code>	Blink the MCC 118 LED.
<code>mcc118_firmware_version()</code>	Get the firmware version.
<code>mcc118_serial()</code>	Read the serial number.
<code>mcc118_calibration_date()</code>	Read the calibration date.
<code>mcc118_calibration_coefficient_read()</code>	Read the calibration coefficients for a channel.
<code>mcc118_calibration_coefficient_write()</code>	Write the calibration coefficients for a channel.
<code>mcc118_a_in_read()</code>	Read an analog input value.
<code>mcc118_trigger_mode()</code>	Set the external trigger input mode.
<code>mcc118_a_in_scan_actual_rate()</code>	Read the actual sample rate for a set of scan parameters.
<code>mcc118_a_in_scan_start()</code>	Start a hardware-paced analog input scan.
<code>mcc118_a_in_scan_buffer_size()</code>	Read the size of the internal scan data buffer.
<code>mcc118_a_in_scan_status()</code>	Read the scan status.
<code>mcc118_a_in_scan_read()</code>	Read scan data and status.
<code>mcc118_a_in_scan_channel_count()</code>	Get the number of channels in the current scan.
<code>mcc118_a_in_scan_stop()</code>	Stop the scan.
<code>mcc118_a_in_scan_cleanup()</code>	Free scan resources.

int **mcc118_open**(uint8_t address)

Open a connection to the MCC 118 device at the specified address.

Parameters

- **address** – The board address (0 - 7).

Returns

Result code, *RESULT_SUCCESS* if successful.

int **mcc118_close**(uint8_t address)

Close a connection to an MCC 118 device and free allocated resources.

Parameters

- **address** – The board address (0 - 7).

Returns

Result code, *RESULT_SUCCESS* if successful.

int **mcc118_is_open**(uint8_t address)

Check if an MCC 118 is open.

Parameters

- **address** – The board address (0 - 7).

Returns

1 if open, 0 if not open.

struct *MCC118DeviceInfo* ***mcc118_info**(void)

Return constant device information for all MCC 118s.

Returns

Pointer to struct *MCC118DeviceInfo*.

int **mcc118_blink_led**(uint8_t address, uint8_t count)

Blink the LED on the MCC 118.

Passing 0 for count will result in the LED blinking continuously until the board is reset or *mcc118_blink_led()* is called again with a non-zero value for count.

Parameters

- **address** – The board address (0 - 7).
- **count** – The number of times to blink (0 - 255).

Returns

Result code, *RESULT_SUCCESS* if successful.

int **mcc118_firmware_version**(uint8_t address, uint16_t *version, uint16_t *boot_version)

Return the board firmware and bootloader versions.

Parameters

- **address** – The board address (0 - 7). Board must already be opened.
- **version** – Receives the firmware version. The version will be in BCD hexadecimal with the high byte as the major version and low byte as minor, i.e. 0x0103 is version 1.03.
- **boot_version** – Receives the bootloader version. The version will be in BCD hexadecimal as above.

Returns

Result code, *RESULT_SUCCESS* if successful.

int **mcc118_serial**(uint8_t address, char *buffer)

Read the MCC 118 serial number.

Parameters

- **address** – The board address (0 - 7). Board must already be opened.
- **buffer** – Pass a user-allocated buffer pointer to receive the serial number as a string. The buffer must be at least 9 characters in length.

Returns

Result code, *RESULT_SUCCESS* if successful.

int **mcc118_calibration_date**(uint8_t address, char *buffer)

Read the MCC 118 calibration date.

Parameters

- **address** – The board address (0 - 7). Board must already be opened.
- **buffer** – Pass a user-allocated buffer pointer to receive the date as a string (format “YYYY-MM-DD”). The buffer must be at least 11 characters in length.

Returns

Result code, *RESULT_SUCCESS* if successful.

int **mcc118_calibration_coefficient_read**(uint8_t address, uint8_t channel, double *slope, double *offset)

Read the MCC 118 calibration coefficients for a single channel.

The coefficients are applied in the library as:

$$\text{calibrated_ADC_code} = (\text{raw_ADC_code} * \text{slope}) + \text{offset}$$

Parameters

- **address** – The board address (0 - 7). Board must already be opened.
- **channel** – The channel number (0 - 7).
- **slope** – Receives the slope.
- **offset** – Receives the offset.

Returns

Result code, *RESULT_SUCCESS* if successful.

int **mcc118_calibration_coefficient_write**(uint8_t address, uint8_t channel, double slope, double offset)

Temporarily write the MCC 118 calibration coefficients for a single channel.

The user can apply their own calibration coefficients by writing to these values. The values will reset to the factory values from the EEPROM whenever *mcc118_open()* is called. This function will fail and return *RESULT_BUSY* if a scan is active when it is called.

The coefficients are applied in the library as:

$$\text{calibrated_ADC_code} = (\text{raw_ADC_code} * \text{slope}) + \text{offset}$$

Parameters

- **address** – The board address (0 - 7). Board must already be opened.
- **channel** – The channel number (0 - 7).
- **slope** – The new slope value.
- **offset** – The new offset value.

Returns

Result code, *RESULT_SUCCESS* if successful.

int **mcc118_a_in_read**(uint8_t address, uint8_t channel, uint32_t options, double *value)

Perform a single reading of an analog input channel and return the value.

The valid options are:

- *OPTS_NOSCALEDATA*: Return ADC code (a value between 0 and 4095) rather than voltage.
- *OPTS_NOCALIBRATEDATA*: Return data without the calibration factors applied.

The options parameter is set to 0 or *OPTS_DEFAULT* for default operation, which is scaled and calibrated data.

Multiple options may be specified by ORing the flags. For instance, specifying *OPTS_NOSCALEDATA* | *OPTS_NOCALIBRATEDATA* will return the value read from the ADC without calibration or converting to voltage.

The function will return *RESULT_BUSY* if called while a scan is running.

Parameters

- **address** – The board address (0 - 7). Board must already be opened.
- **channel** – The analog input channel number, 0 - 7.
- **options** – Options bitmask.
- **value** – Receives the analog input value.

Returns

Result code, *RESULT_SUCCESS* if successful.

```
int mcc118_trigger_mode(uint8_t address, uint8_t mode)
```

Set the trigger input mode.

Parameters

- **address** – The board address (0 - 7). Board must already be opened.
- **mode** – One of the *trigger mode* values.

Returns

Result code, *RESULT_SUCCESS* if successful.

```
int mcc118_a_in_scan_actual_rate(uint8_t channel_count, double sample_rate_per_channel, double  
*actual_sample_rate_per_channel)
```

Read the actual sample rate per channel for a requested sample rate.

The internal scan clock is generated from a 16 MHz clock source so only discrete frequency steps can be achieved. This function will return the actual rate for a requested channel count and rate. This function does not perform any actions with a board, it simply calculates the rate.

Parameters

- **channel_count** – The number of channels in the scan.
- **sample_rate_per_channel** – The desired sampling rate in samples per second per channel, max 100,000.
- **actual_sample_rate_per_channel** – The actual sample rate that would occur when requesting this rate on an MCC 118, or 0 if there is an error.

Returns

Result code, *RESULT_SUCCESS* if successful, *RESULT_BAD_PARAMETER* if the scan parameters are not achievable on an MCC 118.

```
int mcc118_a_in_scan_start(uint8_t address, uint8_t channel_mask, uint32_t samples_per_channel, double  
sample_rate_per_channel, uint32_t options)
```

Start a hardware-paced analog input scan.

The scan runs as a separate thread from the user's code. The function will allocate a scan buffer and read data from the device into that buffer. The user reads the data from this buffer and the scan status using the *mcc118_a_in_scan_read()* function. *mcc118_a_in_scan_stop()* is used to stop a continuous scan, or to stop a finite scan before it completes. The user must call *mcc118_a_in_scan_cleanup()* after the scan has finished and all desired data has been read; this frees all resources from the scan and allows additional scans to be performed.

The scan state has defined terminology:

- **Active:** *mcc118_a_in_scan_start()* has been called and the device may be acquiring data or finished with the acquisition. The scan has not been cleaned up by calling *mcc118_a_in_scan_cleanup()*, so another scan may not be started.
- **Running:** The scan is active and the device is still acquiring data. Certain functions like *mcc118_a_in_read()* will return an error because the device is busy.

The valid options are:

- *OPTS_NOSCALEDATA*: Returns ADC code (a value between 0 and 4095) rather than voltage.
- *OPTS_NOCALIBRATEDATA*: Return data without the calibration factors applied.
- *OPTS_EXTCLOCK*: Use an external 3.3V or 5V logic signal at the CLK input as the scan clock. Multiple devices can be synchronized by connecting the CLK pins together and using this option on all but one device so they will be clocked by the single device using its internal clock. **sample_rate_per_channel** is only used for buffer sizing.
- *OPTS_EXTRIGGER*: Hold off the scan (after calling *mcc118_a_in_scan_start()*) until the trigger condition is met. The trigger is a 3.3V or 5V logic signal applied to the TRIG pin.
- *OPTS_CONTINUOUS*: Scans continuously until stopped by the user by calling *mcc118_a_in_scan_stop()* and writes data to a circular buffer. The data must be read before being overwritten to avoid a buffer overrun error. **samples_per_channel** is only used for buffer sizing.

The options parameter is set to 0 or *OPTS_DEFAULT* for default operation, which is scaled and calibrated data, internal scan clock, no trigger, and finite operation.

Multiple options may be specified by ORing the flags. For instance, specifying *OPTS_NOSCALEDATA* | *OPTS_NOCALIBRATEDATA* will return the values read from the ADC without calibration or converting to voltage.

The buffer size will be allocated as follows:

Finite mode: Total number of samples in the scan

Continuous mode (buffer size is per channel): Either **samples_per_channel** or the value in the following table, whichever is greater

Sample Rate	Buffer Size (per channel)
Not specified	10 kS
0-100 S/s	1 kS
100-10k S/s	10 kS
10k-100k S/s	100 kS

Specifying a very large value for **samples_per_channel** could use too much of the Raspberry Pi memory. If the memory allocation fails, the function will return *RESULT_RESOURCE_UNAVAIL*. The allocation could succeed, but the lack of free memory could cause other problems in the Raspberry Pi. If you need to acquire a high number of samples then it is better to run the scan in continuous mode and stop it when you have acquired the desired amount of data. If a scan is already active this function will return *RESULT_BUSY*.

Parameters

- **address** – The board address (0 - 7). Board must already be opened.
- **channel_mask** – A bit mask of the channels to be scanned. Set each bit to enable the associated channel (0x01 - 0xFF.)
- **samples_per_channel** – The number of samples to acquire for each channel in the scan (finite mode,) or can be used to set a larger scan buffer size than the default value (continuous mode.)
- **sample_rate_per_channel** – The sampling rate in samples per second per channel, max 100,000. When using an external sample clock set this value to the maximum expected rate of the clock.

- **options** – The options bitmask.

Returns

Result code, *RESULT_SUCCESS* if successful, *RESULT_BUSY* if a scan is already active.

int **mcc118_a_in_scan_buffer_size**(uint8_t address, uint32_t *buffer_size_samples)

Returns the size of the internal scan data buffer.

An internal data buffer is allocated for the scan when *mcc118_a_in_scan_start()* is called. This function returns the total size of that buffer in samples.

Parameters

- **address** – The board address (0 - 7). Board must already be opened.
- **buffer_size_samples** – Receives the size of the buffer in samples. Each sample is a **double**.

Returns

Result code, *RESULT_SUCCESS* if successful, *RESULT_RESOURCE_UNAVAIL* if a scan is not currently active, *RESULT_BAD_PARAMETER* if the address is invalid or *buffer_size_samples* is NULL.

int **mcc118_a_in_scan_status**(uint8_t address, uint16_t *status, uint32_t *samples_per_channel)

Reads status and number of available samples from an analog input scan.

The scan is started with *mcc118_a_in_scan_start()* and runs in a background thread that reads the data from the board into an internal scan buffer. This function reads the status of the scan and amount of data in the scan buffer.

Parameters

- **address** – The board address (0 - 7). Board must already be opened.
- **status** – Receives the scan status, an ORed combination of the flags:
 - *STATUS_HW_OVERRUN*: The device scan buffer was not read fast enough and data was lost.
 - *STATUS_BUFFER_OVERRUN*: The thread scan buffer was not read by the user fast enough and data was lost.
 - *STATUS_TRIGGERED*: The trigger conditions have been met.
 - *STATUS_RUNNING*: The scan is running.
- **samples_per_channel** – Receives the number of samples per channel available in the scan thread buffer.

Returns

Result code, *RESULT_SUCCESS* if successful, *RESULT_RESOURCE_UNAVAIL* if a scan has not been started under this instance of the device.

int **mcc118_a_in_scan_read**(uint8_t address, uint16_t *status, int32_t samples_per_channel, double timeout, double *buffer, uint32_t buffer_size_samples, uint32_t *samples_read_per_channel)

Reads status and multiple samples from an analog input scan.

The scan is started with *mcc118_a_in_scan_start()* and runs in a background thread that reads the data from the board into an internal scan buffer. This function reads the data from the scan buffer, and returns the current scan status.

Parameters

- **address** – The board address (0 - 7). Board must already be opened.
- **status** – Receives the scan status, an ORed combination of the flags:

- *STATUS_HW_OVERRUN*: The device scan buffer was not read fast enough and data was lost.
- *STATUS_BUFFER_OVERRUN*: The thread scan buffer was not read by the user fast enough and data was lost.
- *STATUS_TRIGGERED*: The trigger conditions have been met.
- *STATUS_RUNNING*: The scan is running.
- **samples_per_channel** – The number of samples per channel to read. Specify **-1** to read all available samples in the scan thread buffer, ignoring **timeout**. If **buffer** does not contain enough space then the function will read as many samples per channel as will fit in **buffer**.
- **timeout** – The amount of time in seconds to wait for the samples to be read. Specify a negative number to wait indefinitely or **0** to return immediately with whatever samples are available (up to the value of **samples_per_channel** or **buffer_size_samples**.)
- **buffer** – The user data buffer that receives the samples.
- **buffer_size_samples** – The size of the buffer in samples. Each sample is a **double**.
- **samples_read_per_channel** – Returns the actual number of samples read from each channel.

Returns

Result code, *RESULT_SUCCESS* if successful, *RESULT_RESOURCE_UNAVAIL* if a scan is not active.

int **mcc118_a_in_scan_channel_count**(uint8_t address)

Return the number of channels in the current analog input scan.

This function returns 0 if no scan is active.

Parameters

- **address** – The board address (0 - 7). Board must already be opened.

Returns

The number of channels, 0 - 8.

int **mcc118_a_in_scan_stop**(uint8_t address)

Stops an analog input scan.

The scan is stopped immediately. The scan data that has been read into the scan buffer is available until *mcc118_a_in_scan_cleanup()* is called.

Parameters

- **address** – The board address (0 - 7). Board must already be opened.

Returns

Result code, *RESULT_SUCCESS* if successful.

int **mcc118_a_in_scan_cleanup**(uint8_t address)

Free analog input scan resources after the scan is complete.

Parameters

- **address** – The board address (0 - 7). Board must already be opened.

Returns

Result code, *RESULT_SUCCESS* if successful.

4.2.2 Data definitions

4.2.2.1 Device Info

struct **MCC118DeviceInfo**

MCC 118 constant device information.

Public Members

const uint8_t **NUM_AI_CHANNELS**

The number of analog input channels (8.)

const uint16_t **AI_MIN_CODE**

The minimum ADC code (0.)

const uint16_t **AI_MAX_CODE**

The maximum ADC code (4095.)

const double **AI_MIN_VOLTAGE**

The input voltage corresponding to the minimum code (-10.0V.)

const double **AI_MAX_VOLTAGE**

The input voltage corresponding to the maximum code (+10.0V - 1 LSB.)

const double **AI_MIN_RANGE**

The minimum voltage of the input range (-10.0V.)

const double **AI_MAX_RANGE**

The maximum voltage of the input range (+10.0V.)

4.3 MCC 128 functions and data

4.3.1 Functions

Function	Description
<code>mcc128_open()</code>	Open an MCC 128 for use.
<code>mcc128_is_open()</code>	Check if an MCC 128 is open.
<code>mcc128_close()</code>	Close an MCC 128.
<code>mcc128_info()</code>	Return information about this device type.
<code>mcc128_blink_led()</code>	Blink the MCC 128 LED.
<code>mcc128_firmware_version()</code>	Get the firmware version.
<code>mcc128_serial()</code>	Read the serial number.
<code>mcc128_calibration_date()</code>	Read the calibration date.
<code>mcc128_calibration_coefficient_read()</code>	Read the calibration coefficients for a channel.
<code>mcc128_calibration_coefficient_write()</code>	Write the calibration coefficients for a channel.
<code>mcc128_trigger_mode()</code>	Set the external trigger input mode.
<code>mcc128_a_in_mode_read()</code>	Read the analog input mode.
<code>mcc128_a_in_mode_write()</code>	Write the analog input mode.
<code>mcc128_a_in_range_read()</code>	Read the analog input range.
<code>mcc128_a_in_range_write()</code>	Write the analog input range.
<code>mcc128_a_in_read()</code>	Read an analog input value.
<code>mcc128_a_in_scan_actual_rate()</code>	Read the actual sample rate for a set of scan parameters.
<code>mcc128_a_in_scan_start()</code>	Start a hardware-paced analog input scan.
<code>mcc128_a_in_scan_buffer_size()</code>	Read the size of the internal scan data buffer.
<code>mcc128_a_in_scan_status()</code>	Read the scan status.
<code>mcc128_a_in_scan_read()</code>	Read scan data and status.
<code>mcc128_a_in_scan_channel_count()</code>	Get the number of channels in the current scan.
<code>mcc128_a_in_scan_stop()</code>	Stop the scan.
<code>mcc128_a_in_scan_cleanup()</code>	Free scan resources.

int **mcc128_open**(uint8_t address)

Open a connection to the MCC 128 device at the specified address.

Parameters

- **address** – The board address (0 - 7).

Returns

Result code, *RESULT_SUCCESS* if successful.

int **mcc128_close**(uint8_t address)

Close a connection to an MCC 128 device and free allocated resources.

Parameters

- **address** – The board address (0 - 7).

Returns

Result code, *RESULT_SUCCESS* if successful.

int **mcc128_is_open**(uint8_t address)

Check if an MCC 128 is open.

Parameters

- **address** – The board address (0 - 7).

Returns

1 if open, 0 if not open.

struct *MCC128DeviceInfo* ***mcc128_info**(void)

Return constant device information for all MCC 128s.

Returns

Pointer to struct *MCC128DeviceInfo*.

int **mcc128_blink_led**(uint8_t address, uint8_t count)

Blink the LED on the MCC 128.

Passing 0 for count will result in the LED blinking continuously until the board is reset or *mcc128_blink_led()* is called again with a non-zero value for count.

Parameters

- **address** – The board address (0 - 7).
- **count** – The number of times to blink (0 - 255).

Returns

Result code, *RESULT_SUCCESS* if successful.

int **mcc128_firmware_version**(uint8_t address, uint16_t *version)

Return the board firmware version.

Parameters

- **address** – The board address (0 - 7). Board must already be opened.
- **version** – Receives the firmware version. The version will be in BCD hexadecimal with the high byte as the major version and low byte as minor, i.e. 0x0103 is version 1.03.

Returns

Result code, *RESULT_SUCCESS* if successful.

int **mcc128_serial**(uint8_t address, char *buffer)

Read the MCC 128 serial number.

Parameters

- **address** – The board address (0 - 7). Board must already be opened.
- **buffer** – Pass a user-allocated buffer pointer to receive the serial number as a string. The buffer must be at least 9 characters in length.

Returns

Result code, *RESULT_SUCCESS* if successful.

int **mcc128_calibration_date**(uint8_t address, char *buffer)

Read the MCC 128 calibration date.

Parameters

- **address** – The board address (0 - 7). Board must already be opened.
- **buffer** – Pass a user-allocated buffer pointer to receive the date as a string (format “YYYY-MM-DD”). The buffer must be at least 11 characters in length.

Returns

Result code, *RESULT_SUCCESS* if successful.

int **mcc128_calibration_coefficient_read**(uint8_t address, uint8_t range, double *slope, double *offset)

Read the MCC 128 calibration coefficients for a specified input range.

The coefficients are applied in the library as:

$$\text{calibrated_ADC_code} = (\text{raw_ADC_code} * \text{slope}) + \text{offset}$$

Parameters

- **address** – The board address (0 - 7). Board must already be opened.
- **range** – The input range, one of the *input range* values.
- **slope** – Receives the slope.
- **offset** – Receives the offset.

Returns

Result code, *RESULT_SUCCESS* if successful.

int **mcc128_calibration_coefficient_write**(uint8_t address, uint8_t range, double slope, double offset)

Temporarily write the MCC 128 calibration coefficients for a specified input range.

The user can apply their own calibration coefficients by writing to these values. The values will reset to the factory values from the EEPROM whenever *mcc128_open()* is called. This function will fail and return *RESULT_BUSY* if a scan is active when it is called.

The coefficients are applied in the library as:

$$\text{calibrated_ADC_code} = (\text{raw_ADC_code} * \text{slope}) + \text{offset}$$

Parameters

- **address** – The board address (0 - 7). Board must already be opened.
- **range** – The input range, one of the *input range* values.
- **slope** – The new slope value.
- **offset** – The new offset value.

Returns

Result code, *RESULT_SUCCESS* if successful.

int **mcc128_a_in_mode_read**(uint8_t address, uint8_t *mode)

Read the analog input mode.

Reads the current analog *input mode*.

Parameters

- **address** – The board address (0 - 7). Board must already be opened.
- **mode** – Receives the *input mode*.

Returns

Result code, *RESULT_SUCCESS* if successful.

int **mcc128_a_in_mode_write**(uint8_t address, uint8_t mode)

Set the analog input mode.

This sets the analog inputs to one of the valid values:

- *A_IN_MODE_SE*: Single-ended (8 inputs relative to ground.)
- *A_IN_MODE_DIFF*: Differential (4 channels with positive and negative inputs.)

This function will fail and return *RESULT_BUSY* if a scan is active when it is called.

Parameters

- **address** – The board address (0 - 7). Board must already be opened.
- **mode** – One of the *input mode* values.

Returns

Result code, *RESULT_SUCCESS* if successful.

int **mcc128_a_in_range_read**(uint8_t address, uint8_t *range)

Read the analog input range.

Returns the current analog *input range*.

Parameters

- **address** – The board address (0 - 7). Board must already be opened.
- **range** – Receives the *input range*.

Returns

Result code, *RESULT_SUCCESS* if successful.

int **mcc128_a_in_range_write**(uint8_t address, uint8_t range)

Set the analog input range.

This sets the analog input range to one of the valid ranges:

- *A_IN_RANGE_BIP_10V*: +/- 10V
- *A_IN_RANGE_BIP_5V*: +/- 5V
- *A_IN_RANGE_BIP_2V*: +/- 2V
- *A_IN_RANGE_BIP_1V*: +/- 1V

This function will fail and return *RESULT_BUSY* if a scan is active when it is called.

Parameters

- **address** – The board address (0 - 7). Board must already be opened.
- **range** – One of the *input range* values.

Returns

Result code, *RESULT_SUCCESS* if successful.

int **mcc128_trigger_mode**(uint8_t address, uint8_t mode)

Set the trigger input mode.

Parameters

- **address** – The board address (0 - 7). Board must already be opened.
- **mode** – One of the *trigger mode* values.

Returns

Result code, *RESULT_SUCCESS* if successful.

int **mcc128_a_in_read**(uint8_t address, uint8_t channel, uint32_t options, double *value)

Perform a single reading of an analog input channel and return the value.

The valid options are:

- *OPTS_NOSCALEDATA*: Return ADC code (a value between 0 and 65535) rather than voltage.
- *OPTS_NOCALIBRATEDATA*: Return data without the calibration factors applied.

The options parameter is set to 0 or *OPTS_DEFAULT* for default operation, which is scaled and calibrated data.

Multiple options may be specified by ORing the flags. For instance, specifying *OPTS_NOSCALEDATA* | *OPTS_NOCALIBRATEDATA* will return the value read from the ADC without calibration or converting to voltage.

The function will return *RESULT_BUSY* if called while a scan is running.

Parameters

- **address** – The board address (0 - 7). Board must already be opened.
- **channel** – The analog input channel number, 0 - 7.
- **options** – Options bitmask.
- **value** – Receives the analog input value.

Returns

Result code, *RESULT_SUCCESS* if successful.

int **mcc128_a_in_scan_actual_rate**(uint8_t channel_count, double sample_rate_per_channel, double *actual_sample_rate_per_channel)

Read the actual sample rate per channel for a requested sample rate.

The internal scan clock is generated from a 16 MHz clock source so only discrete frequency steps can be achieved. This function will return the actual rate for a requested channel count and rate. This function does not perform any actions with a board, it simply calculates the rate.

Parameters

- **channel_count** – The number of channels in the scan.
- **sample_rate_per_channel** – The desired sampling rate in samples per second per channel, max 100,000.
- **actual_sample_rate_per_channel** – The actual sample rate that would occur when requesting this rate on an MCC 128, or 0 if there is an error.

Returns

Result code, *RESULT_SUCCESS* if successful, *RESULT_BAD_PARAMETER* if the scan parameters are not achievable on an MCC 128.

int **mcc128_a_in_scan_start**(uint8_t address, uint8_t channel_mask, uint32_t samples_per_channel, double sample_rate_per_channel, uint32_t options)

Start a hardware-paced analog input scan.

The scan runs as a separate thread from the user's code. The function will allocate a scan buffer and read data from the device into that buffer. The user reads the data from this buffer and the scan status using the *mcc128_a_in_scan_read()* function. *mcc128_a_in_scan_stop()* is used to stop a continuous scan, or to stop a finite scan before it completes. The user must call *mcc128_a_in_scan_cleanup()* after the scan has finished and all desired data has been read; this frees all resources from the scan and allows additional scans to be performed.

The scan state has defined terminology:

- **Active:** `mcc128_a_in_scan_start()` has been called and the device may be acquiring data or finished with the acquisition. The scan has not been cleaned up by calling `mcc128_a_in_scan_cleanup()`, so another scan may not be started.
- **Running:** The scan is active and the device is still acquiring data. Certain functions like `mcc128_a_in_read()` will return an error because the device is busy.

The valid options are:

- `OPTS_NOSCALEDATA`: Returns ADC code (a value between 0 and 65535) rather than voltage.
- `OPTS_NOCALIBRATEDATA`: Return data without the calibration factors applied.
- `OPTS_EXTCLOCK`: Use an external 3.3V or 5V logic signal at the CLK input as the scan clock. Multiple devices can be synchronized by connecting the CLK pins together and using this option on all but one device so they will be clocked by the single device using its internal clock. `sample_rate_per_channel` is only used for buffer sizing.
- `OPTS_EXTRIGGER`: Hold off the scan (after calling `mcc128_a_in_scan_start()`) until the trigger condition is met. The trigger is a 3.3V or 5V logic signal applied to the TRIG pin.
- `OPTS_CONTINUOUS`: Scans continuously until stopped by the user by calling `mcc128_a_in_scan_stop()` and writes data to a circular buffer. The data must be read before being overwritten to avoid a buffer overrun error. `samples_per_channel` is only used for buffer sizing.

The options parameter is set to 0 or `OPTS_DEFAULT` for default operation, which is scaled and calibrated data, internal scan clock, no trigger, and finite operation.

Multiple options may be specified by ORing the flags. For instance, specifying `OPTS_NOSCALEDATA | OPTS_NOCALIBRATEDATA` will return the values read from the ADC without calibration or converting to voltage.

The buffer size will be allocated as follows:

Finite mode: Total number of samples in the scan

Continuous mode (buffer size is per channel): Either `samples_per_channel` or the value in the following table, whichever is greater

Sample Rate	Buffer Size (per channel)
Not specified	10 kS
0-100 S/s	1 kS
100-10k S/s	10 kS
10k-100k S/s	100 kS

Specifying a very large value for `samples_per_channel` could use too much of the Raspberry Pi memory. If the memory allocation fails, the function will return `RESULT_RESOURCE_UNAVAIL`. The allocation could succeed, but the lack of free memory could cause other problems in the Raspberry Pi. If you need to acquire a high number of samples then it is better to run the scan in continuous mode and stop it when you have acquired the desired amount of data. If a scan is already active this function will return `RESULT_BUSY`.

Parameters

- **address** – The board address (0 - 7). Board must already be opened.
- **channel_mask** – A bit mask of the channels to be scanned. Set each bit to enable the associated channel (0x01 - 0xFF.)

- **samples_per_channel** – The number of samples to acquire for each channel in the scan (finite mode), or can be used to set a larger scan buffer size than the default value (continuous mode.)
- **sample_rate_per_channel** – The sampling rate in samples per second per channel, max 100,000. When using an external sample clock set this value to the maximum expected rate of the clock.
- **options** – The options bitmask.

Returns

Result code, *RESULT_SUCCESS* if successful, *RESULT_BUSY* if a scan is already active.

int **mcc128_a_in_scan_buffer_size**(uint8_t address, uint32_t *buffer_size_samples)

Returns the size of the internal scan data buffer.

An internal data buffer is allocated for the scan when *mcc128_a_in_scan_start()* is called. This function returns the total size of that buffer in samples.

Parameters

- **address** – The board address (0 - 7). Board must already be opened.
- **buffer_size_samples** – Receives the size of the buffer in samples. Each sample is a **double**.

Returns

Result code, *RESULT_SUCCESS* if successful, *RESULT_RESOURCE_UNAVAIL* if a scan is not currently active, *RESULT_BAD_PARAMETER* if the address is invalid or *buffer_size_samples* is NULL.

int **mcc128_a_in_scan_status**(uint8_t address, uint16_t *status, uint32_t *samples_per_channel)

Reads status and number of available samples from an analog input scan.

The scan is started with *mcc128_a_in_scan_start()* and runs in a background thread that reads the data from the board into an internal scan buffer. This function reads the status of the scan and amount of data in the scan buffer.

Parameters

- **address** – The board address (0 - 7). Board must already be opened.
- **status** – Receives the scan status, an ORed combination of the flags:
 - *STATUS_HW_OVERRUN*: The device scan buffer was not read fast enough and data was lost.
 - *STATUS_BUFFER_OVERRUN*: The thread scan buffer was not read by the user fast enough and data was lost.
 - *STATUS_TRIGGERED*: The trigger conditions have been met.
 - *STATUS_RUNNING*: The scan is running.
- **samples_per_channel** – Receives the number of samples per channel available in the scan thread buffer.

Returns

Result code, *RESULT_SUCCESS* if successful, *RESULT_RESOURCE_UNAVAIL* if a scan has not been started under this instance of the device.

int **mcc128_a_in_scan_read**(uint8_t address, uint16_t *status, int32_t samples_per_channel, double timeout, double *buffer, uint32_t buffer_size_samples, uint32_t *samples_read_per_channel)

Reads status and multiple samples from an analog input scan.

The scan is started with `mcc128_a_in_scan_start()` and runs in a background thread that reads the data from the board into an internal scan buffer. This function reads the data from the scan buffer, and returns the current scan status.

Parameters

- **address** – The board address (0 - 7). Board must already be opened.
- **status** – Receives the scan status, an ORed combination of the flags:
 - `STATUS_HW_OVERRUN`: The device scan buffer was not read fast enough and data was lost.
 - `STATUS_BUFFER_OVERRUN`: The thread scan buffer was not read by the user fast enough and data was lost.
 - `STATUS_TRIGGERED`: The trigger conditions have been met.
 - `STATUS_RUNNING`: The scan is running.
- **samples_per_channel** – The number of samples per channel to read. Specify `-1` to read all available samples in the scan thread buffer, ignoring **timeout**. If **buffer** does not contain enough space then the function will read as many samples per channel as will fit in **buffer**.
- **timeout** – The amount of time in seconds to wait for the samples to be read. Specify a negative number to wait indefinitely or `0` to return immediately with whatever samples are available (up to the value of **samples_per_channel** or **buffer_size_samples**.)
- **buffer** – The user data buffer that receives the samples.
- **buffer_size_samples** – The size of the buffer in samples. Each sample is a **double**.
- **samples_read_per_channel** – Returns the actual number of samples read from each channel.

Returns

Result code, `RESULT_SUCCESS` if successful, `RESULT_RESOURCE_UNAVAIL` if a scan is not active.

int `mcc128_a_in_scan_channel_count`(uint8_t address)

Return the number of channels in the current analog input scan.

This function returns 0 if no scan is active.

Parameters

- **address** – The board address (0 - 7). Board must already be opened.

Returns

The number of channels, 0 - 8.

int `mcc128_a_in_scan_stop`(uint8_t address)

Stops an analog input scan.

The scan is stopped immediately. The scan data that has been read into the scan buffer is available until `mcc128_a_in_scan_cleanup()` is called.

Parameters

- **address** – The board address (0 - 7). Board must already be opened.

Returns

Result code, `RESULT_SUCCESS` if successful.

int **mcc128_a_in_scan_cleanup**(uint8_t address)

Free analog input scan resources after the scan is complete.

Parameters

- **address** – The board address (0 - 7). Board must already be opened.

Returns

Result code, *RESULT_SUCCESS* if successful.

4.3.2 Data definitions

4.3.2.1 Device Info

struct **MCC128DeviceInfo**

MCC 128 constant device information.

Public Members

const uint8_t **NUM_AI_MODES**

The number of analog input modes (2.)

const uint8_t **NUM_AI_CHANNELS**[2]

The number of analog input channels in each mode (8, 4.)

const uint16_t **AI_MIN_CODE**

The minimum ADC code (0.)

const uint16_t **AI_MAX_CODE**

The maximum ADC code (65535.)

const uint8_t **NUM_AI_RANGES**

The number of analog input ranges (4.)

const double **AI_MIN_VOLTAGE**[4]

The input voltage corresponding to the minimum code in each range (-10.0V, -5.0V, -2.0V, -1.0V.)

const double **AI_MAX_VOLTAGE**[4]

The input voltage corresponding to the maximum code in each range (+10.0V - 1 LSB, +5.0V - 1 LSB, +2.0V - 1 LSB, +1.0V - 1 LSB.)

const double **AI_MIN_RANGE**[4]

The minimum voltage of the input range in each range (-10.0V, -5.0V, -2.0V, -1.0V.)

const double **AI_MAX_RANGE**[4]

The maximum voltage of the input range in each range (+10.0V, +5.0V, +2.0V, +1.0V.)

4.3.2.2 Analog Input Modes

enum **AnalogInputMode**

Analog input modes.

Values:

enumerator **A_IN_MODE_SE**

Single-ended.

enumerator **A_IN_MODE_DIFF**

Differential.

4.3.2.3 Analog Input Ranges

enum **AnalogInputRange**

Analog input ranges.

Values:

enumerator **A_IN_RANGE_BIP_10V**

+/- 10 V

enumerator **A_IN_RANGE_BIP_5V**

+/- 5 V

enumerator **A_IN_RANGE_BIP_2V**

+/- 2 V

enumerator **A_IN_RANGE_BIP_1V**

+/- 1 V

4.4 MCC 134 functions and data

4.4.1 Functions

Function	Description
<code>mcc134_open()</code>	Open an MCC 134 for use.
<code>mcc134_is_open()</code>	Check if an MCC 134 is open.
<code>mcc134_close()</code>	Close an MCC 134.
<code>mcc134_info()</code>	Return information about this device type.
<code>mcc134_serial()</code>	Read the serial number.
<code>mcc134_calibration_date()</code>	Read the calibration date.
<code>mcc134_calibration_coefficient_read()</code>	Read the calibration coefficients for a channel.
<code>mcc134_calibration_coefficient_write()</code>	Write the calibration coefficients for a channel.
<code>mcc134_tc_type_write()</code>	Write the thermocouple type for a channel.
<code>mcc134_tc_type_read()</code>	Read the thermocouple type for a channel.
<code>mcc134_update_interval_write()</code>	Write the temperature update interval.
<code>mcc134_update_interval_read()</code>	Read the temperature update interval.
<code>mcc134_t_in_read()</code>	Read a temperature input value.
<code>mcc134_a_in_read()</code>	Read an analog input value.
<code>mcc134_cjc_read()</code>	Read a CJC temperature.

int **mcc134_open**(uint8_t address)

Open a connection to the MCC 134 device at the specified address.

Parameters

- **address** – The board address (0 - 7).

Returns

Result code, RESULT_SUCCESS if successful.

int **mcc134_is_open**(uint8_t address)

Check if an MCC 134 is open.

Parameters

- **address** – The board address (0 - 7).

Returns

1 if open, 0 if not open.

int **mcc134_close**(uint8_t address)

Close a connection to an MCC 134 device and free allocated resources.

Parameters

- **address** – The board address (0 - 7).

Returns

Result code, RESULT_SUCCESS if successful.

struct *MCC134DeviceInfo* ***mcc134_info**(void)

Return constant device information for all MCC 134s.

Returns

Pointer to struct *MCC134DeviceInfo*.

int **mcc134_serial**(uint8_t address, char *buffer)

Read the MCC 134 serial number.

Parameters

- **address** – The board address (0 - 7). Board must already be opened.
- **buffer** – Pass a user-allocated buffer pointer to receive the serial number as a string. The buffer must be at least 9 characters in length.

Returns

Result code, RESULT_SUCCESS if successful.

int **mcc134_calibration_date**(uint8_t address, char *buffer)

Read the MCC 134 calibration date.

Parameters

- **address** – The board address (0 - 7). Board must already be opened.
- **buffer** – Pass a user-allocated buffer pointer to receive the date as a string (format “YYYY-MM-DD”). The buffer must be at least 11 characters in length.

Returns

Result code, RESULT_SUCCESS if successful.

int **mcc134_calibration_coefficient_read**(uint8_t address, uint8_t channel, double *slope, double *offset)

Read the MCC 134 calibration coefficients for a single channel.

The coefficients are applied in the library as:

$$\text{calibrated_ADC_code} = (\text{raw_ADC_code} * \text{slope}) + \text{offset}$$

Parameters

- **address** – The board address (0 - 7). Board must already be opened.
- **channel** – The channel number (0 - 3).
- **slope** – Receives the slope.
- **offset** – Receives the offset.

Returns

Result code, RESULT_SUCCESS if successful.

int **mcc134_calibration_coefficient_write**(uint8_t address, uint8_t channel, double slope, double offset)

Temporarily write the MCC 134 calibration coefficients for a single channel.

The user can apply their own calibration coefficients by writing to these values. The values will reset to the factory values from the EEPROM whenever *mcc134_open()* is called.

The coefficients are applied in the library as:

$$\text{calibrated_ADC_code} = (\text{raw_ADC_code} * \text{slope}) + \text{offset}$$

Parameters

- **address** – The board address (0 - 7). Board must already be opened.
- **channel** – The channel number (0 - 3).
- **slope** – The new slope value.

- **offset** – The new offset value.

Returns

Result code, *RESULT_SUCCESS* if successful.

int **mcc134_tc_type_write**(uint8_t address, uint8_t channel, uint8_t type)

Write the thermocouple type for a channel.

Tells the MCC 134 library what thermocouple type is connected to the specified channel and enables the channel. This is required for correct temperature calculations. The type is one of *TcTypes* and the board will default to all disabled (set to *TC_DISABLED*) when it is first opened.

Parameters

- **address** – The board address (0 - 7). Board must already be opened.
- **channel** – The analog input channel number (0 - 3).
- **type** – The thermocouple type, one of *TcTypes*.

Returns

Result code, *RESULT_SUCCESS* if successful.

int **mcc134_tc_type_read**(uint8_t address, uint8_t channel, uint8_t *type)

Read the thermocouple type for a channel.

Reads the current thermocouple type for the specified channel. The type is one of *TcTypes* and the board will default to all channels disabled (set to *TC_DISABLED*) when it is first opened.

Parameters

- **address** – The board address (0 - 7). Board must already be opened.
- **channel** – The analog input channel number (0 - 3).
- **type** – Receives the thermocouple type, one of *TcTypes*.

Returns

Result code, *RESULT_SUCCESS* if successful.

int **mcc134_update_interval_write**(uint8_t address, uint8_t interval)

Write the temperature update interval.

Tells the MCC 134 library how often to update temperatures, with the interval specified in seconds. The library defaults to updating every second, but you may increase this interval if you do not plan to call *mcc134_t_in_read()* very often. This will reduce the load on shared resources for other DAQ HATs.

Parameters

- **address** – The board address (0 - 7). Board must already be opened.
- **interval** – The interval in seconds (1 - 255).

Returns

Result code, *RESULT_SUCCESS* if successful.

int **mcc134_update_interval_read**(uint8_t address, uint8_t *interval)

Read the temperature update interval.

Reads the library temperature update rate in seconds.

Parameters

- **address** – The board address (0 - 7). Board must already be opened.

- **interval** – Receives the update rate.

Returns

Result code, *RESULT_SUCCESS* if successful.

int **mcc134_t_in_read**(uint8_t address, uint8_t channel, double *value)

Read a temperature input channel.

Reads the specified channel and returns the value as degrees Celsius. The channel must be enabled with *mcc134_tc_type_write()* or the function will return *RESULT_BAD_PARAMETER*.

This function returns immediately with the most recent internal temperature reading for the specified channel. When a board is open, the library will read each channel once per second. This interval can be increased with *mcc134_update_interval_write()*. There will be a delay when the board is first opened because the read thread has to read the cold junction compensation sensors and thermocouple inputs before it can return the first value.

The returned temperature can have some special values to indicate abnormal conditions:

- *OPEN_TC_VALUE* if an open thermocouple is detected on the channel.
- *OVERRANGE_TC_VALUE* if an overrange is detected on the channel.
- *COMMON_MODE_TC_VALUE* if a common-mode error is detected on the channel. This occurs when thermocouples attached to the board are at different voltages.

Parameters

- **address** – The board address (0 - 7). Board must already be opened.
- **channel** – The analog input channel number (0 - 3.)
- **value** – Receives the temperature value in degrees C.

Returns

Result code, *RESULT_SUCCESS* if successful.

int **mcc134_a_in_read**(uint8_t address, uint8_t channel, uint32_t options, double *value)

Read an analog input channel and return the value.

This function returns immediately with the most recent voltage or ADC code reading for the specified channel. The channel must be enabled with *mcc134_tc_type_write()* or the function will return *RESULT_BAD_PARAMETER*.

The library reads the ADC at the time interval set with *mcc134_update_interval_write()*, which defaults to 1 second. This interval may be increased with *mcc134_update_interval_write()*.

The returned voltage can have a special value to indicate abnormal conditions:

- *COMMON_MODE_TC_VALUE* if a common-mode error is detected on the channel. This occurs when thermocouples attached to the board are at different voltages.

The valid options are:

- *OPTS_NOSCALEDATA*: Return ADC code (a value between -8,388,608 and 8,388,607) rather than voltage.
- *OPTS_NOCALIBRATEDATA*: Return data without the calibration factors applied.

The options parameter is set to 0 or *OPTS_DEFAULT* for default operation, which is scaled and calibrated data.

Multiple options may be specified by ORing the flags. For instance, specifying *OPTS_NOSCALEDATA* | *OPTS_NOCALIBRATEDATA* will return the value read from the ADC without calibration or converting to voltage.

Parameters

- **address** – The board address (0 - 7). Board must already be opened.
- **channel** – The analog input channel number (0 - 3).
- **options** – Options bitmask.
- **value** – Receives the analog input value.

Returns

Result code, RESULT_SUCCESS if successful.

int **mcc134_cjc_read**(uint8_t address, uint8_t channel, double *value)

Read the cold junction compensation temperature for a specified channel.

Returns the most recent cold junction sensor temperature for the specified thermocouple terminal. The library automatically performs cold junction compensation, so this function is only needed for informational use or if you want to perform your own compensation. The temperature is returned in degrees C.

The library reads the cold junction compensation sensors at the time interval set with *mcc134_update_interval_write()*, which defaults to 1 second. This interval may be increased with *mcc134_update_interval_write()*.

Parameters

- **address** – The board address (0 - 7). Board must already be opened.
- **channel** – The analog input channel number, 0 - 3.
- **value** – Receives the read value.

Returns

Result code, RESULT_SUCCESS if successful.

4.4.2 Data definitions

OPEN_TC_VALUE (-9999.0)

Return value for an open thermocouple.

OVERRRANGE_TC_VALUE (-8888.0)

Return value for thermocouple voltage outside the valid range.

COMMON_MODE_TC_VALUE (-7777.0)

Return value for thermocouple voltage outside the common-mode range.

4.4.2.1 Device Info

struct **MCC134DeviceInfo**

MCC 134 constant device information.

Public Members

const uint8_t **NUM_AI_CHANNELS**

The number of analog input channels (4.)

const int32_t **AI_MIN_CODE**

The minimum ADC code (-8,388,608.)

const int32_t **AI_MAX_CODE**

The maximum ADC code (8,388,607.)

const double **AI_MIN_VOLTAGE**

The input voltage corresponding to the minimum code (-0.078125V.)

const double **AI_MAX_VOLTAGE**

The input voltage corresponding to the maximum code (+0.078125V - 1 LSB.)

const double **AI_MIN_RANGE**

The minimum voltage of the input range (-0.078125V.)

const double **AI_MAX_RANGE**

The maximum voltage of the input range (0.078125V.)

4.4.2.2 Thermocouple Types

enum **TcTypes**

Thermocouple type constants.

Values:

enumerator **TC_TYPE_J**

J type.

enumerator **TC_TYPE_K**

K type.

enumerator **TC_TYPE_T**

T type

enumerator **TC_TYPE_E**

E type

enumerator **TC_TYPE_R**

R type.

enumerator **TC_TYPE_S**

S type.

enumerator **TC_TYPE_B**

B type.

enumerator **TC_TYPE_N**

N type.

enumerator **TC_DISABLED**

Input disabled.

4.5 MCC 152 functions and data

4.5.1 Functions

Function	Description
<code>mcc152_open()</code>	Open an MCC 152 for use.
<code>mcc152_is_open()</code>	Check if an MCC 152 is open.
<code>mcc152_close()</code>	Close an MCC 152.
<code>mcc152_info()</code>	Return information about this device type.
<code>mcc152_serial()</code>	Read the serial number.
<code>mcc152_a_out_write()</code>	Write an analog output channel value.
<code>mcc152_a_out_write_all()</code>	Write all analog output channels simultaneously.
<code>mcc152_dio_reset()</code>	Reset the digital I/O to the default configuration.
<code>mcc152_dio_input_read_bit()</code>	Read a digital input.
<code>mcc152_dio_input_read_port()</code>	Read all digital inputs.
<code>mcc152_dio_output_write_bit()</code>	Write a digital output.
<code>mcc152_dio_output_write_port()</code>	Write all digital outputs.
<code>mcc152_dio_output_read_bit()</code>	Read the state of a digital output.
<code>mcc152_dio_output_read_port()</code>	Read the state of all digital outputs.
<code>mcc152_dio_int_status_read_bit()</code>	Read the interrupt status for a single channel.
<code>mcc152_dio_int_status_read_port()</code>	Read the interrupt status for all channels.
<code>mcc152_dio_config_write_bit()</code>	Write a digital I/O configuration item value for a single channel.
<code>mcc152_dio_config_write_port()</code>	Write a digital I/O configuration item value for all channels.
<code>mcc152_dio_config_read_bit()</code>	Read a digital I/O configuration item value for a single channel.
<code>mcc152_dio_config_read_port()</code>	Read a digital I/O configuration item value for all channels.

int **mcc152_open**(uint8_t address)

Open a connection to the MCC 152 device at the specified address.

Parameters

- **address** – The board address (0 - 7).

Returns

Result code, RESULT_SUCCESS if successful.

int **mcc152_is_open**(uint8_t address)

Check if an MCC 152 is open.

Parameters

- **address** – The board address (0 - 7).

Returns

1 if open, 0 if not open.

int **mcc152_close**(uint8_t address)

Close a connection to an MCC 152 device and free allocated resources.

Parameters

- **address** – The board address (0 - 7).

Returns

Result code, *RESULT_SUCCESS* if successful.

struct *MCC152DeviceInfo* ***mcc152_info**(void)

Return constant device information for all MCC 152s.

Returns

Pointer to struct *MCC152DeviceInfo*.

int **mcc152_serial**(uint8_t address, char *buffer)

Read the MCC 152 serial number.

Parameters

- **address** – The board address (0 - 7). Board must already be opened.
- **buffer** – Pass a user-allocated buffer pointer to receive the serial number as a string. The buffer must be at least 9 characters in length.

Returns

Result code, *RESULT_SUCCESS* if successful.

int **mcc152_a_out_write**(uint8_t address, uint8_t channel, uint32_t options, double value)

Perform a write to an analog output channel.

Updates the analog output channel in either volts or DAC code (set the *OPTS_NOSCALEDATA* option to use DAC code.) The voltage must be 0.0 - 5.0 and DAC code 0.0 - 4095.0.

Parameters

- **address** – The board address (0 - 7). Board must already be opened.
- **channel** – The analog output channel number, 0 - 1.
- **options** – Options bitmask
- **value** – The analog output value.

Returns

Result code, *RESULT_SUCCESS* if successful.

int **mcc152_a_out_write_all**(uint8_t address, uint32_t options, double *values)

Perform a write to all analog output channels simultaneously.

Update all analog output channels in either volts or DAC code (set the *OPTS_NOSCALEDATA* option to use DAC code.) The outputs will update at the same time.

Parameters

- **address** – The board address (0 - 7). Board must already be opened.
- **options** – Options bitmask
- **values** – The array of analog output values; there must be at least 2 values, but only the first two values will be used.

Returns

Result code, RESULT_SUCCESS if successful.

int **mcc152_dio_reset**(uint8_t address)

Reset the digital I/O to the default configuration.

- All channels input
- Output registers set to 1
- Input inversion disabled
- No input latching
- Pull-up resistors enabled
- All interrupts disabled
- Push-pull output type

Parameters

- **address** – The board address (0 - 7). Board must already be opened.

Returns

Result code, RESULT_SUCCESS if successful.

int **mcc152_dio_input_read_bit**(uint8_t address, uint8_t channel, uint8_t *value)

Read a single digital input channel.

Returns 0 or 1 in **value**. If the specified channel is configured as an output this will return the value present at the terminal.

This function reads the entire input register, so care must be taken when latched inputs are enabled. If a latched input changes between input reads then changes back to its original value, the next input read will report the change to the first value then the following read will show the original value. If another input is read then this input change could be missed so it is best to use *mcc152_dio_input_read_port()* when using latched inputs.

Parameters

- **address** – The board address (0 - 7). Board must already be opened.
- **channel** – The DIO channel number, 0 - 7.
- **value** – Receives the input value.

Returns

Result code, RESULT_SUCCESS if successful.

int **mcc152_dio_input_read_port**(uint8_t address, uint8_t *value)

Read all digital input channels simultaneously.

Returns an 8-bit value in **value** representing all channels in channel order (bit 0 is channel 0, etc.) If a channel is configured as an output this will return the value present at the terminal.

Care must be taken when latched inputs are enabled. If a latched input changes between input reads then changes back to its original value, the next input read will report the change to the first value then the following read will show the original value.

Parameters

- **address** – The board address (0 - 7). Board must already be opened.
- **value** – Receives the input values.

Returns

Result code, RESULT_SUCCESS if successful.

int **mcc152_dio_output_write_bit**(uint8_t address, uint8_t channel, uint8_t value)

Write a single digital output channel.

If the specified channel is configured as an input this will not have any effect at the terminal, but allows the output register to be loaded before configuring the channel as an output.

Parameters

- **address** – The board address (0 - 7). Board must already be opened.
- **channel** – The DIO channel number, 0 - 7.
- **value** – The output value (0 or 1)

Returns

Result code, RESULT_SUCCESS if successful.

int **mcc152_dio_output_write_port**(uint8_t address, uint8_t value)

Write all digital output channels simultaneously.

Pass an 8-bit value in **value** representing the desired output for all channels in channel order (bit 0 is channel 0, etc.)

If the specified channel is configured as an input this will not have any effect at the terminal, but allows the output register to be loaded before configuring the channel as an output.

For example, to set channels 0 - 3 to 0 and channels 4 - 7 to 1 call:

```
mcc152_dio_output_write(address, 0xF0);
```

Parameters

- **address** – The board address (0 - 7). Board must already be opened.
- **value** – The output values.

Returns

Result code, RESULT_SUCCESS if successful.

int **mcc152_dio_output_read_bit**(uint8_t address, uint8_t channel, uint8_t *value)

Read a single digital output register.

Returns 0 or 1 in **value**.

This function returns the value stored in the output register. It may not represent the value at the terminal if the channel is configured as input or open-drain output.

Parameters

- **address** – The board address (0 - 7). Board must already be opened.

- **channel** – The DIO channel number, 0 - 7.
- **value** – Receives the output value.

Returns

Result code, RESULT_SUCCESS if successful.

int **mcc152_dio_output_read_port**(uint8_t address, uint8_t *value)

Read all digital output registers simultaneously.

Returns an 8-bit value in **value** representing all channels in channel order (bit 0 is channel 0, etc.)

This function returns the value stored in the output register. It may not represent the value at the terminal if the channel is configured as input or open-drain output.

Parameters

- **address** – The board address (0 - 7). Board must already be opened.
- **value** – Receives the output values.

Returns

Result code, RESULT_SUCCESS if successful.

int **mcc152_dio_int_status_read_bit**(uint8_t address, uint8_t channel, uint8_t *value)

Read the interrupt status for a single channel.

Returns 0 when the channel is not generating an interrupt, 1 when the channel is generating an interrupt.

Parameters

- **address** – The board address (0 - 7). Board must already be opened.
- **channel** – The DIO channel number, 0 - 7.
- **value** – Receives the interrupt status value.

Returns

Result code, RESULT_SUCCESS if successful.

int **mcc152_dio_int_status_read_port**(uint8_t address, uint8_t *value)

Read the interrupt status for all channels.

Returns an 8-bit value in **value** representing all channels in channel order (bit 0 is channel 0, etc.) A 0 in a bit indicates the corresponding channel is not generating an interrupt, a 1 indicates the channel is generating an interrupt.

Parameters

- **address** – The board address (0 - 7). Board must already be opened.
- **value** – Receives the interrupt status value.

Returns

Result code, RESULT_SUCCESS if successful.

int **mcc152_dio_config_write_bit**(uint8_t address, uint8_t channel, uint8_t item, uint8_t value)

Write a digital I/O configuration value for a single channel.

There are several configuration items that may be written for the digital I/O. The item is selected with the **item** argument, which may be one of the *DIOConfigItem* values:

- *DIO_DIRECTION*: Set the digital I/O channel direction by passing 0 for output and 1 for input.
- *DIO_PULL_CONFIG*: Configure the pull-up/down resistor by passing 0 for pull-down or 1 for pull-up. The resistor may be enabled or disabled with the *DIO_PULL_ENABLE* item.

- *DIO_PULL_ENABLE*: Enable or disable the pull-up/down resistor by passing 0 for disabled or 1 for enabled. The resistor is configured for pull-up/down with the *DIO_PULL_CONFIG* item. The resistor is automatically disabled if the bit is set to output and is configured as open-drain.
- *DIO_INPUT_INVERT*: Enable inverting the input by passing a 0 for normal input or 1 for inverted.
- *DIO_INPUT_LATCH*: Enable input latching by passing 0 for non-latched or 1 for latched.

When the input is non-latched, reads show the current status of the input. A state change in the input generates an interrupt (if it is not masked). A read of the input clears the interrupt. If the input goes back to its initial logic state before the input is read, then the interrupt is cleared.

When the input is latched, a change of state of the input generates an interrupt and the input logic value is loaded into the input port register. A read of the input will clear the interrupt. If the input returns to its initial logic state before the input is read, then the interrupt is not cleared and the input register keeps the logic value that initiated the interrupt. The next read of the input will show the initial state. Care must be taken when using bit reads on the input when latching is enabled - the bit function still reads the entire input register so a change on another bit could be missed. It is best to use port input reads when using latching.

If the input is changed from latched to non-latched, a read from the input reflects the current terminal logic level. If the input is changed from non-latched to latched input, the read from the input represents the latched logic level.

- *DIO_OUTPUT_TYPE*: Set the output type by writing 0 for push-pull or 1 for open-drain. This setting affects all outputs so is not a per-channel setting and the channel argument will be ignored. It should be set to the desired type before using the *DIO_DIRECTION* item to set channels as outputs. Internal pull-up/down resistors are disabled when a bit is set to output and is configured as open-drain, so external resistors should be used.
- *DIO_INT_MASK*: Enable or disable interrupt generation for the input by masking the interrupt. Write 0 to enable the interrupt or 1 to disable it.

All MCC 152s share a single interrupt signal to the CPU, so when an interrupt occurs the user must determine the source, optionally act on the interrupt, then clear that source so that other interrupts may be detected. The current interrupt state may be read with *hat_interrupt_state()*. A user program may wait for the interrupt to become active with *hat_wait_for_interrupt()*, or may register an interrupt callback function with *hat_interrupt_callback_enable()*. This allows the user to wait for a change on one or more inputs without constantly reading the inputs. The source of the interrupt may be determined by reading the interrupt status of each MCC 152 with *mcc152_dio_int_status_read_bit()* or *mcc152_dio_int_status_read_port()*, and all active interrupt sources must be cleared before the interrupt will become inactive. The interrupt is cleared by reading the input(s) with *mcc152_dio_input_read_bit()* or *mcc152_dio_input_read_port()*.

Parameters

- **address** – The board address (0 - 7). Board must already be opened.
- **channel** – The digital I/O channel, 0 - 7.
- **item** – The config item, one of *DIOConfigItem*.
- **value** – The config value.

Returns

Result code, *RESULT_SUCCESS* if successful.

```
int mcc152_dio_config_write_port(uint8_t address, uint8_t item, uint8_t value)
```

Write a digital I/O configuration value for all channels.

There are several configuration items that may be written for the digital I/O. They are written for all channels at once using the 8-bit value passed in **value**, where each bit corresponds to a channel (bit 0 is channel 0, etc.) The item is selected with the **item** argument, which may be one of the *DIOConfigItem* values:

- *DIO_DIRECTION*: Set the digital I/O channel directions by passing 0 in a bit for output and 1 for input.
- *DIO_PULL_CONFIG*: Configure the pull-up/down resistors by passing 0 in a bit for pull-down or 1 for pull-up. The resistors may be enabled or disabled with the *DIO_PULL_ENABLE* item.
- *DIO_PULL_ENABLE*: Enable or disable pull-up/down resistors by passing 0 in a bit for disabled or 1 for enabled. The resistors are configured for pull-up/down with the *DIO_PULL_CONFIG* item. The resistors are automatically disabled if a bit is set to output and is configured as open-drain.
- *DIO_INPUT_INVERT*: Enable inverting inputs by passing a 0 in a bit for normal input or 1 for inverted.
- *DIO_INPUT_LATCH*: Enable input latching by passing 0 in a bit for non-latched or 1 for latched.

When the input is non-latched, reads show the current status of the input. A state change in the corresponding input generates an interrupt (if it is not masked). A read of the input clears the interrupt. If the input goes back to its initial logic state before the input is read, then the interrupt is cleared.

When the input is latched, a change of state of the input generates an interrupt and the input logic value is loaded into the input port register. A read of the input will clear the interrupt. If the input returns to its initial logic state before the input is read, then the interrupt is not cleared and the input register keeps the logic value that initiated the interrupt. The next read of the input will show the initial state. Care must be taken when using bit reads on the input when latching is enabled - the bit function still reads the entire input register so a change on another bit could be missed. It is best to use port input reads when using latching.

If the input is changed from latched to non-latched, a read from the input reflects the current terminal logic level. If the input is changed from non-latched to latched input, the read from the input represents the latched logic level.

- *DIO_OUTPUT_TYPE*: Set the output type by writing 0 for push-pull or 1 for open-drain. This setting affects all outputs so is not a per-channel setting. It should be set to the desired type before using *DIO_DIRECTION* to set channels as outputs. Internal pull-up/down resistors are disabled when a bit is set to output and is configured as open-drain, so external resistors should be used.
- *DIO_INT_MASK*: Enable or disable interrupt generation for specific inputs by masking the interrupts. Write 0 in a bit to enable the interrupt from that channel or 1 to disable it.

All MCC 152s share a single interrupt signal to the CPU, so when an interrupt occurs the user must determine the source, optionally act on the interrupt, then clear that source so that other interrupts may be detected. The current interrupt state may be read with *hat_interrupt_state()*. A user program may wait for the interrupt to become active with *hat_wait_for_interrupt()*, or may register an interrupt callback function with *hat_interrupt_callback_enable()*. This allows the user to wait for a change on one or more inputs without constantly reading the inputs. The source of the interrupt may be determined by reading the interrupt status of each MCC 152 with *mcc152_dio_int_status_read_bit()* or *mcc152_dio_int_status_read_port()*, and all active interrupt sources must be cleared before the interrupt will become inactive. The interrupt is cleared by reading the input(s) with *mcc152_dio_input_read_bit()* or *mcc152_dio_input_read_port()*.

Parameters

- **address** – The board address (0 - 7). Board must already be opened.
- **item** – The config item, one of *DIOConfigItem*.
- **value** – The config value.

Returns

Result code, *RESULT_SUCCESS* if successful.

```
int mcc152_dio_config_read_bit(uint8_t address, uint8_t channel, uint8_t item, uint8_t *value)
```

Read a digital I/O configuration value for a single channel.

There are several configuration items that may be read for the digital I/O. The item is selected with the **item** argument, which may be one of the *DIOConfigItem* values:

- *DIO_DIRECTION*: Read the digital I/O channel direction setting, where 0 is output and 1 is input.
- *DIO_PULL_CONFIG*: Read the pull-up/down resistor configuration where 0 is pull-down and 1 is pull-up.
- *DIO_PULL_ENABLE*: Read the pull-up/down resistor enable setting where 0 is disabled and 1 is enabled.
- *DIO_INPUT_INVERT*: Read the input invert setting where 0 is normal input and 1 is inverted.
- *DIO_INPUT_LATCH*: Read the input latching setting where 0 is non-latched and 1 is latched.
- *DIO_OUTPUT_TYPE*: Read the output type setting where 0 is push-pull and 1 is open-drain. This setting affects all outputs so is not a per-channel setting and the channel argument is ignored.
- *DIO_INT_MASK*: Read the interrupt mask setting where 0 enables the interrupt and 1 disables it.

Parameters

- **address** – The board address (0 - 7). Board must already be opened.
- **channel** – The digital I/O channel, 0 - 7.
- **item** – The config item, one of *DIOConfigItem*.
- **value** – Receives the config value.

Returns

Result code, *RESULT_SUCCESS* if successful.

```
int mcc152_dio_config_read_port(uint8_t address, uint8_t item, uint8_t *value)
```

Read a digital I/O configuration value for all channels.

There are several configuration items that may be read for the digital I/O. They are read for all channels at once, returning an 8-bit value in **value**, where each bit corresponds to a channel (bit 0 is channel 0, etc.) The item is selected with the **item** argument, which may be one of the *DIOConfigItem* values:

- *DIO_DIRECTION*: Read the digital I/O channels direction settings, where 0 for a bit is output and 1 is input.
- *DIO_PULL_CONFIG*: Read the pull-up/down resistor configurations where 0 for a bit is pull-down and 1 is pull-up.
- *DIO_PULL_ENABLE*: Read the pull-up/down resistor enable settings where 0 for a bit is disabled and 1 is enabled.
- *DIO_INPUT_INVERT*: Read the input invert settings where 0 for a bit is normal input and 1 is inverted.
- *DIO_INPUT_LATCH*: Read the input latching settings where 0 for a bit is non-latched and 1 is latched.
- *DIO_OUTPUT_TYPE*: Read the output type setting where 0 is push-pull and 1 is open-drain. This setting affects all outputs so is not a per-channel setting.
- *DIO_INT_MASK*: Read the interrupt mask settings where 0 enables the interrupt from the corresponding channel and 1 disables it.

Parameters

- **address** – The board address (0 - 7). Board must already be opened.
- **item** – The config item, one of *DIOConfigItem*.
- **value** – Receives the config value.

Returns

Result code, *RESULT_SUCCESS* if successful.

4.5.2 Data types and definitions**4.5.2.1 Device Info**

struct **MCC152DeviceInfo**

MCC 152 constant device information.

Public Members

const uint8_t **NUM_DIO_CHANNELS**

The number of digital I/O channels (8.)

const uint8_t **NUM_AO_CHANNELS**

The number of analog output channels (2.)

const uint16_t **AO_MIN_CODE**

The minimum DAC code (0.)

const uint16_t **AO_MAX_CODE**

The maximum DAC code (4095.)

const double **AO_MIN_VOLTAGE**

The output voltage corresponding to the minimum code (0.0V.)

const double **AO_MAX_VOLTAGE**

The output voltage corresponding to the maximum code (+5.0V - 1 LSB.)

const double **AO_MIN_RANGE**

The minimum voltage of the output range (0.0V.)

const double **AO_MAX_RANGE**

The maximum voltage of the output range (+5.0V.)

4.5.2.2 DIO Config Items

enum **DIOConfigItem**

DIO Configuration Items.

Values:

enumerator **DIO_DIRECTION**

Configure channel direction.

- enumerator **DIO_PULL_CONFIG**
Configure pull-up/down resistor.
- enumerator **DIO_PULL_ENABLE**
Enable pull-up/down resistor.
- enumerator **DIO_INPUT_INVERT**
Configure input inversion.
- enumerator **DIO_INPUT_LATCH**
Configure input latching.
- enumerator **DIO_OUTPUT_TYPE**
Configure output type.
- enumerator **DIO_INT_MASK**
Configure interrupt mask.

4.6 MCC 172 functions and data

4.6.1 Functions

Function	Description
<i>mcc172_open()</i>	Open an MCC 172 for use.
<i>mcc172_is_open()</i>	Check if an MCC 172 is open.
<i>mcc172_close()</i>	Close an MCC 172.
<i>mcc172_info()</i>	Return information about this device type.
<i>mcc172_blink_led()</i>	Blink the MCC 172 LED.
<i>mcc172_firmware_version()</i>	Get the firmware version.
<i>mcc172_serial()</i>	Read the serial number.
<i>mcc172_calibration_date()</i>	Read the calibration date.
<i>mcc172_calibration_coefficient_read()</i>	Read the calibration coefficients for a channel.
<i>mcc172_calibration_coefficient_write()</i>	Write the calibration coefficients for a channel.
<i>mcc172_iepe_config_read()</i>	Read the IEPE configuration for a channel.
<i>mcc172_iepe_config_write()</i>	Write the IEPE configuration for a channel.
<i>mcc172_a_in_sensitivity_read()</i>	Read the sensitivity scaling for a channel.
<i>mcc172_a_in_sensitivity_write()</i>	Write the sensitivity scaling for a channel.
<i>mcc172_a_in_clock_config_read()</i>	Read the sampling clock configuration.
<i>mcc172_a_in_clock_config_write()</i>	Write the sampling clock configuration.
<i>mcc172_trigger_config()</i>	Configure the external trigger input.
<i>mcc172_a_in_scan_start()</i>	Start a hardware-paced analog input scan.
<i>mcc172_a_in_scan_buffer_size()</i>	Read the size of the internal scan data buffer.
<i>mcc172_a_in_scan_status()</i>	Read the scan status.
<i>mcc172_a_in_scan_read()</i>	Read scan data and status.
<i>mcc172_a_in_scan_channel_count()</i>	Get the number of channels in the current scan.
<i>mcc172_a_in_scan_stop()</i>	Stop the scan.
<i>mcc172_a_in_scan_cleanup()</i>	Free scan resources.

int **mcc172_open**(uint8_t address)

Open a connection to the MCC 172 device at the specified address.

Parameters

- **address** – The board address (0 - 7).

Returns

Result code, RESULT_SUCCESS if successful.

int **mcc172_close**(uint8_t address)

Close a connection to an MCC 172 device and free allocated resources.

Parameters

- **address** – The board address (0 - 7).

Returns

Result code, RESULT_SUCCESS if successful.

int **mcc172_is_open**(uint8_t address)

Check if an MCC 172 is open.

Parameters

- **address** – The board address (0 - 7).

Returns

1 if open, 0 if not open.

struct *MCC172DeviceInfo* ***mcc172_info**(void)

Return constant device information for all MCC 172s.

Returns

Pointer to struct *MCC172DeviceInfo*.

int **mcc172_blink_led**(uint8_t address, uint8_t count)

Blink the LED on the MCC 172.

Passing 0 for count will result in the LED blinking continuously until the board is reset or *mcc172_blink_led()* is called again with a non-zero value for count.

Parameters

- **address** – The board address (0 - 7).
- **count** – The number of times to blink (0 - 255).

Returns

Result code, RESULT_SUCCESS if successful.

int **mcc172_firmware_version**(uint8_t address, uint16_t *version)

Return the board firmware version.

Parameters

- **address** – The board address (0 - 7). Board must already be opened.
- **version** – Receives the firmware version. The version will be in BCD hexadecimal with the high byte as the major version and low byte as minor, i.e. 0x0103 is version 1.03.

Returns

Result code, RESULT_SUCCESS if successful.

int **mcc172_serial**(uint8_t address, char *buffer)

Read the MCC 172 serial number.

Parameters

- **address** – The board address (0 - 7). Board must already be opened.
- **buffer** – Pass a user-allocated buffer pointer to receive the serial number as a string. The buffer must be at least 9 characters in length.

Returns

Result code, RESULT_SUCCESS if successful.

int **mcc172_calibration_date**(uint8_t address, char *buffer)

Read the MCC 172 calibration date.

Parameters

- **address** – The board address (0 - 7). Board must already be opened.
- **buffer** – Pass a user-allocated buffer pointer to receive the date as a string (format “YYYY-MM-DD”). The buffer must be at least 11 characters in length.

Returns

Result code, RESULT_SUCCESS if successful.

int **mcc172_calibration_coefficient_read**(uint8_t address, uint8_t channel, double *slope, double *offset)

Read the MCC 172 calibration coefficients for a single channel.

The coefficients are applied in the library as:

$$\text{calibrated_ADC_code} = (\text{raw_ADC_code} - \text{offset}) * \text{slope}$$

Parameters

- **address** – The board address (0 - 7). Board must already be opened.
- **channel** – The channel number (0 - 1).
- **slope** – Receives the slope.
- **offset** – Receives the offset.

Returns

Result code, RESULT_SUCCESS if successful.

int **mcc172_calibration_coefficient_write**(uint8_t address, uint8_t channel, double slope, double offset)

Temporarily write the MCC 172 calibration coefficients for a single channel.

The user can apply their own calibration coefficients by writing to these values. The values will reset to the factory values from the EEPROM whenever *mcc172_open()* is called. This function will fail and return *RESULT_BUSY* if a scan is active when it is called.

The coefficients are applied in the library as:

$$\text{calibrated_ADC_code} = (\text{raw_ADC_code} - \text{offset}) * \text{slope}$$

Parameters

- **address** – The board address (0 - 7). Board must already be opened.
- **channel** – The channel number (0 - 1).

- **slope** – The new slope value.
- **offset** – The new offset value.

Returns

Result code, *RESULT_SUCCESS* if successful.

```
int mcc172_iepe_config_read(uint8_t address, uint8_t channel, uint8_t *config)
```

Read the MCC 172 IEPE configuration for a single channel.

Parameters

- **address** – The board address (0 - 7). Board must already be opened.
- **channel** – The channel number (0 - 1).
- **config** – Receives the configuration for the specified channel:
 - 0: IEPE power off
 - 1: IEPE power on

Returns

Result code, *RESULT_SUCCESS* if successful.

```
int mcc172_iepe_config_write(uint8_t address, uint8_t channel, uint8_t config)
```

Write the MCC 172 IEPE configuration for a single channel.

Writes the new IEPE configuration for a channel. This function will fail and return *RESULT_BUSY* if a scan is active when it is called.

Parameters

- **address** – The board address (0 - 7). Board must already be opened.
- **channel** – The channel number (0 - 1).
- **config** – The IEPE configuration for the specified channel:
 - 0: IEPE power off
 - 1: IEPE power on

Returns

Result code, *RESULT_SUCCESS* if successful.

```
int mcc172_a_in_sensitivity_read(uint8_t address, uint8_t channel, double *value)
```

Read the MCC 172 analog input sensitivity scaling factor for a single channel.

The sensitivity is specified in mV / mechanical unit. The default value when opening the library is 1000, resulting in no scaling of the input voltage.

Parameters

- **address** – The board address (0 - 7). Board must already be opened.
- **channel** – The channel number (0 - 1).
- **value** – Receives the sensitivity for the specified channel

Returns

Result code, *RESULT_SUCCESS* if successful.

int **mcc172_a_in_sensitivity_write**(uint8_t address, uint8_t channel, double value)

Write the MCC 172 analog input sensitivity scaling factor for a single channel.

This applies a scaling factor to the analog input data so it returns values that are meaningful for the connected sensor.

The sensitivity is specified in mV / mechanical unit. The default value when opening the library is 1000, resulting in no scaling of the input voltage. Changing this value will not change the values reported by *mcc172_info()* since it is simply sensor scaling applied to the data before returning it.

Examples:

- A seismic sensor with a sensitivity of 10 V/g. Set the sensitivity to 10,000 and the returned data will be in units of g.
- A vibration sensor with a sensitivity of 100 mV/g. Set the sensitivity to 100 and the returned data will be in units of g.

This function will fail and return *RESULT_BUSY* if a scan is active when it is called.

Parameters

- **address** – The board address (0 - 7). Board must already be opened.
- **channel** – The channel number (0 - 1).
- **value** – The sensitivity for the specified channel.

Returns

Result code, *RESULT_SUCCESS* if successful.

int **mcc172_a_in_clock_config_read**(uint8_t address, uint8_t *clock_source, double *sample_rate_per_channel, uint8_t *synced)

Read the sampling clock configuration.

This function will return the sample clock configuration and rate. If the clock is configured for local or master source, then the rate will be the internally adjusted rate set by the user. If the clock is configured for slave source, then the rate will be measured from the master clock after the synchronization period has ended. The synchronization status is also returned.

The clock source will be one of the following values:

- *SOURCE_LOCAL*: The clock is generated on this MCC 172 and not shared with other MCC 172s.
- *SOURCE_MASTER*: The clock is generated on this MCC 172 and is shared as the master clock for other MCC 172s.
- *SOURCE_SLAVE*: No clock is generated on this MCC 172, it receives its clock from the master MCC 172.

The data rate will not be valid in slave mode if synced is equal to 0. The device will not detect a loss of the master clock when in slave mode; it only monitors the clock when a sync is initiated.

Parameters

- **address** – The board address (0 - 7). Board must already be opened.
- **clock_source** – Receives the ADC clock source, one of the *source type* values.
- **sample_rate_per_channel** – Receives the sample rate in samples per second per channel
- **synced** – Receives the synchronization status (0: sync in progress, 1: sync complete)

Returns

Result code, *RESULT_SUCCESS* if successful

int **mcc172_a_in_clock_config_write**(uint8_t address, uint8_t clock_source, double sample_rate_per_channel)

Write the sampling clock configuration.

This function will configure the ADC sampling clock. The default configuration after opening the device is local mode, 51.2 KHz data rate.

The clock_source must be one of:

- *SOURCE_LOCAL*: The clock is generated on this MCC 172 and not shared with other MCC 172s.
- *SOURCE_MASTER*: The clock is generated on this MCC 172 and is shared as the master clock for other MCC 172s. All other MCC 172s must be configured for local or slave clock.
- *SOURCE_SLAVE*: No clock is generated on this MCC 172, it receives its clock from the master MCC 172.

The ADCs will be synchronized so they sample the inputs at the same time. This requires 128 clock cycles before the first sample is available. When using a master - slave clock configuration for multiple MCC 172s there are additional considerations:

- There should be only one master device; otherwise, you will be connecting multiple outputs together and could damage a device.
- Configure the clock on the slave device(s) first, master last. The synchronization will occur when the master clock is configured, causing the ADCs on all the devices to be in sync.
- If you change the clock configuration on one device after configuring the master, then the data will no longer be in sync. The devices cannot detect this and will still report that they are synchronized. Always write the clock configuration to all devices when modifying the configuration.
- Slave devices must have a master clock source or scans will never complete.
- A trigger must be used for the data streams from all devices to start on the same sample.

The MCC 172 can generate an ADC sampling clock equal to 51.2 kHz divided by an integer between 1 and 256. The data_rate_per_channel will be internally converted to the nearest valid rate. The actual rate can be read back using *mcc172_a_in_clock_config_read()*. When used in slave clock configuration, the device will measure the frequency of the incoming master clock after the synchronization period is complete. Calling *mcc172_a_in_clock_config_read()* after this will return the measured data rate.

Parameters

- **address** – The board address (0 - 7). Board must already be opened.
- **clock_source** – The ADC clock source, one of the *source type* values.
- **sample_rate_per_channel** – The requested sample rate in samples per second per channel

Returns

Result code, *RESULT_SUCCESS* if successful

int **mcc172_trigger_config**(uint8_t address, uint8_t source, uint8_t mode)

Configure the digital trigger.

The analog input scan may be configured to start saving the acquired data when the digital trigger is in the desired state. A single device trigger may also be shared with multiple boards. This command sets the trigger source and mode.

The trigger source must be one of:

- *SOURCE_LOCAL*: The trigger terminal on this MCC 172 is used and not shared with other MCC 172s.
- *SOURCE_MASTER*: The trigger terminal on this MCC 172 is used and is shared as the master trigger for other MCC 172s.
- *SOURCE_SLAVE*: The trigger terminal on this MCC 172 is not used, it receives its trigger from the master MCC 172.

The trigger mode must be one of:

- *TRIG_RISING_EDGE*: Start the scan on a rising edge of TRIG.
- *TRIG_FALLING_EDGE*: Start the scan on a falling edge of TRIG.
- *TRIG_ACTIVE_HIGH*: Start the scan any time TRIG is high.
- *TRIG_ACTIVE_LOW*: Start the scan any time TRIG is low.

Due to the nature of the filtering in the A/D converters there is an input delay of 39 samples, so the data coming from the converters at any time is delayed by 39 samples from the current time. This is most noticeable when using a trigger - there will be approximately 39 samples prior to the trigger event in the captured data.

Care must be taken when using master / slave triggering; the input trigger signal on the master will be passed through to the slave(s), but the mode is set independently on each device. For example, it is possible for the master to trigger on the rising edge of the signal and the slave to trigger on the falling edge.

Parameters

- **address** – The board address (0 - 7). Board must already be opened.
- **source** – The trigger source, one of the *source type* values.
- **mode** – The trigger mode, one of the *trigger mode* values.

Returns

Result code, *RESULT_SUCCESS* if successful.

```
int mcc172_a_in_scan_start(uint8_t address, uint8_t channel_mask, uint32_t samples_per_channel, uint32_t options)
```

Start capturing analog input data from the specified channels.

The scan runs as a separate thread from the user's code. The function will allocate a scan buffer and read data from the device into that buffer. The user reads the data from this buffer and the scan status using the *mcc172_a_in_scan_read()* function. *mcc172_a_in_scan_stop()* is used to stop a continuous scan, or to stop a finite scan before it completes. The user must call *mcc172_a_in_scan_cleanup()* after the scan has finished and all desired data has been read; this frees all resources from the scan and allows additional scans to be performed.

The scan cannot be started until the ADCs are synchronized, so this function will not return until that has completed. It is best to wait for sync using *mcc172_a_in_clock_config_read()* before starting the scan.

The scan state has defined terminology:

- **Active:** *mcc172_a_in_scan_start()* has been called and the device may be acquiring data or finished with the acquisition. The scan has not been cleaned up by calling *mcc172_a_in_scan_cleanup()*, so another scan may not be started.
- **Running:** The scan is active and the device is still acquiring data. Certain functions will return an error because the device is busy.

The valid options are:

- *OPTS_NOSCALEDATA*: Returns ADC code (a value between AI_MIN_CODE and AI_MAX_CODE) rather than voltage.
- *OPTS_NOCALIBRATEDATA*: Return data without the calibration factors applied.
- *OPTS_EXTTRIGGER*: Hold off the scan (after calling *mcc172_a_in_scan_start()*) until the trigger condition is met.
- *OPTS_CONTINUOUS*: Scans continuously until stopped by the user by calling *mcc172_a_in_scan_stop()* and writes data to a circular buffer. The data must be read before being overwritten to avoid a buffer overrun error. **samples_per_channel** is only used for buffer sizing.

The *OPTS_EXTCLOCK* option is not supported for this device and will return an error.

The options parameter is set to 0 or *OPTS_DEFAULT* for default operation, which is scaled and calibrated data, no trigger, and finite operation.

Multiple options may be specified by ORing the flags. For instance, specifying *OPTS_NOSCALEDATA* | *OPTS_NOCALIBRATEDATA* will return the values read from the ADC without calibration or converting to voltage.

The buffer size will be allocated as follows:

Finite mode: Total number of samples in the scan

Continuous mode (buffer size is per channel): Either **samples_per_channel** or the value in the following table, whichever is greater

Sample Rate	Buffer Size (per channel)
200-1024 S/s	1 kS
1280-10.24 kS/s	10 kS
12.8, 25.6, 51.2 kS/s	100 kS

Specifying a very large value for **samples_per_channel** could use too much of the Raspberry Pi memory. If the memory allocation fails, the function will return *RESULT_RESOURCE_UNAVAIL*. The allocation could succeed, but the lack of free memory could cause other problems in the Raspberry Pi. If you need to acquire a high number of samples then it is better to run the scan in continuous mode and stop it when you have acquired the desired amount of data. If a scan is already active this function will return *RESULT_BUSY*.

Parameters

- **address** – The board address (0 - 7). Board must already be opened.
- **channel_mask** – A bit mask of the channels to be scanned. Set each bit to enable the associated channel (0x01 - 0x03.)
- **samples_per_channel** – The number of samples to acquire for each channel in the scan (finite mode,) or can be used to set a larger scan buffer size than the default value (continuous mode.)
- **options** – The options bitmask.

Returns

Result code, *RESULT_SUCCESS* if successful, *RESULT_BUSY* if a scan is already active.

```
int mcc172_a_in_scan_buffer_size(uint8_t address, uint32_t *buffer_size_samples)
```

Returns the size of the internal scan data buffer.

An internal data buffer is allocated for the scan when `mcc172_a_in_scan_start()` is called. This function returns the total size of that buffer in samples.

Parameters

- **address** – The board address (0 - 7). Board must already be opened.
- **buffer_size_samples** – Receives the size of the buffer in samples. Each sample is a **double**.

Returns

Result code, `RESULT_SUCCESS` if successful, `RESULT_RESOURCE_UNAVAIL` if a scan is not currently active, `RESULT_BAD_PARAMETER` if the address is invalid or `buffer_size_samples` is NULL.

int `mcc172_a_in_scan_status`(uint8_t address, uint16_t *status, uint32_t *samples_per_channel)

Reads status and number of available samples from an analog input scan.

The scan is started with `mcc172_a_in_scan_start()` and runs in a background thread that reads the data from the board into an internal scan buffer. This function reads the status of the scan and amount of data in the scan buffer.

Parameters

- **address** – The board address (0 - 7). Board must already be opened.
- **status** – Receives the scan status, an ORed combination of the flags:
 - `STATUS_HW_OVERRUN`: The device scan buffer was not read fast enough and data was lost.
 - `STATUS_BUFFER_OVERRUN`: The thread scan buffer was not read by the user fast enough and data was lost.
 - `STATUS_TRIGGERED`: The trigger conditions have been met.
 - `STATUS_RUNNING`: The scan is running.
- **samples_per_channel** – Receives the number of samples per channel available in the scan thread buffer.

Returns

Result code, `RESULT_SUCCESS` if successful, `RESULT_RESOURCE_UNAVAIL` if a scan has not been started under this instance of the device.

int `mcc172_a_in_scan_read`(uint8_t address, uint16_t *status, int32_t samples_per_channel, double timeout, double *buffer, uint32_t buffer_size_samples, uint32_t *samples_read_per_channel)

Reads status and multiple samples from an analog input scan.

The scan is started with `mcc172_a_in_scan_start()` and runs in a background thread that reads the data from the board into an internal scan buffer. This function reads the data from the scan buffer, and returns the current scan status.

Parameters

- **address** – The board address (0 - 7). Board must already be opened.
- **status** – Receives the scan status, an ORed combination of the flags:
 - `STATUS_HW_OVERRUN`: The device scan buffer was not read fast enough and data was lost.
 - `STATUS_BUFFER_OVERRUN`: The thread scan buffer was not read by the user fast enough and data was lost.
 - `STATUS_TRIGGERED`: The trigger conditions have been met.

- *STATUS_RUNNING*: The scan is running.
- **samples_per_channel** – The number of samples per channel to read. Specify **-1** to read all available samples in the scan thread buffer, ignoring **timeout**. If **buffer** does not contain enough space then the function will read as many samples per channel as will fit in **buffer**.
- **timeout** – The amount of time in seconds to wait for the samples to be read. Specify a negative number to wait indefinitely or **0** to return immediately with whatever samples are available (up to the value of **samples_per_channel** or **buffer_size_samples**.)
- **buffer** – The user data buffer that receives the samples.
- **buffer_size_samples** – The size of the buffer in samples. Each sample is a **double**.
- **samples_read_per_channel** – Returns the actual number of samples read from each channel.

Returns

Result code, *RESULT_SUCCESS* if successful, *RESULT_RESOURCE_UNAVAIL* if a scan is not active.

int **mcc172_a_in_scan_channel_count**(uint8_t address)

Return the number of channels in the current analog input scan.

This function returns 0 if no scan is active.

Parameters

- **address** – The board address (0 - 7). Board must already be opened.

Returns

The number of channels, 0 - 2.

int **mcc172_a_in_scan_stop**(uint8_t address)

Stops an analog input scan.

The scan is stopped immediately. The scan data that has been read into the scan buffer is available until *mcc172_a_in_scan_cleanup()* is called.

Parameters

- **address** – The board address (0 - 7). Board must already be opened.

Returns

Result code, *RESULT_SUCCESS* if successful.

int **mcc172_a_in_scan_cleanup**(uint8_t address)

Free analog input scan resources after the scan is complete.

Parameters

- **address** – The board address (0 - 7). Board must already be opened.

Returns

Result code, *RESULT_SUCCESS* if successful.

4.6.2 Data definitions

4.6.2.1 Device Info

struct **MCC172DeviceInfo**

MCC 172 constant device information.

Public Members

const uint8_t **NUM_AI_CHANNELS**

The number of analog input channels (2.)

const int32_t **AI_MIN_CODE**

The minimum ADC code (-8,388,608.)

const int32_t **AI_MAX_CODE**

The maximum ADC code (8,388,607.)

const double **AI_MIN_VOLTAGE**

The input voltage corresponding to the minimum code (-5.0V.)

const double **AI_MAX_VOLTAGE**

The input voltage corresponding to the maximum code (+5.0V - 1 LSB.)

const double **AI_MIN_RANGE**

The minimum voltage of the input range (-5.0V.)

const double **AI_MAX_RANGE**

The maximum voltage of the input range (+5.0V.)

4.6.2.2 Source Types

enum **SourceType**

Clock / trigger source definitions.

Values:

enumerator **SOURCE_LOCAL**

Use a local-only source.

enumerator **SOURCE_MASTER**

Use a local source and set it as master.

enumerator **SOURCE_SLAVE**

Use a separate master source.

PYTHON LIBRARY REFERENCE

The Python library is organized as a global method for listing the DAQ HAT boards attached to your system, and board-specific classes to provide full functionality for each type of board. The Python package is named *daqhats*.

5.1 Global methods and data

5.1.1 Methods

Method	Description
<i>hat_list()</i>	Return a list of detected DAQ HAT boards.
<i>interrupt_state()</i>	Read the current DAQ HAT interrupt status.
<i>wait_for_interrupt()</i>	Wait for a DAQ HAT interrupt to occur.
<i>interrupt_callback_enable()</i>	Enable an interrupt callback function.
<i>interrupt_callback_disable()</i>	Disable interrupt callback function.

`daqhats.hat_list(filter_by_id=0)`

Return a list of detected DAQ HAT boards.

Scans certain locations for information from the HAT EEPROMs. Verifies the contents are valid HAT EEPROM contents and returns a list of namedtuples containing information on the HAT. Info will only be returned for DAQ HATs. The EEPROM contents are stored in `/etc/mcc/hats` when using the `daqhats_read_eeproms` tool, or in `/proc/device-tree` in the case of a single HAT at address 0.

Parameters

filter_by_id (*int*) – If this is *HatIDs.ANY* return all DAQ HATs found. Otherwise, return only DAQ HATs with ID matching this value.

Returns

A list of namedtuples, the number of elements match the number of DAQ HATs found. Each namedtuple will contain the following field names:

- **address** (*int*): device address
- **id** (*int*): device product ID, identifies the type of DAQ HAT
- **version** (*int*): device hardware version
- **product_name** (*str*): device product name

Return type

list

daqhats.interrupt_state()

Read the current DAQ HAT interrupt status

Returns the status of the interrupt signal, True if active or False if inactive. The signal can be shared by multiple DAQ HATs so the status of each board that may generate an interrupt must be read and the interrupt source(s) cleared before the interrupt will become inactive.

This function only applies when using devices that can generate an interrupt:

- MCC 152

Returns

The interrupt status.

Return type

bool

daqhats.wait_for_interrupt(timeout)

Wait for an interrupt from a DAQ HAT to occur.

Pass a timeout in seconds. Pass -1 to wait forever or 0 to return immediately. If the interrupt has not occurred before the timeout elapses the function will return False.

This function only applies when using devices that can generate an interrupt:

- MCC 152

Returns

The interrupt status - True = interrupt active, False = interrupt inactive.

Return type

bool

daqhats.interrupt_callback_enable(callback, user_data)

Enable an interrupt callback function.

Set a function that will be called when a DAQ HAT interrupt occurs.

The function will be called when the DAQ HAT interrupt signal becomes active, and cannot be called again until the interrupt signal becomes inactive. Active sources become inactive when manually cleared (such as reading the digital I/O inputs or clearing the interrupt enable.) If not latched, an active source also becomes inactive when the value returns to the original value (the value at the source before the interrupt was generated.)

There may only be one callback function at a time; if you call this when a function is already set as the callback function then it will be replaced with the new function and the old function will no longer be called if an interrupt occurs. The data argument to this function will be passed to the callback function when it is called.

The callback function must have the form “callback(user_data)”. For example:

```
def my_function(data):
    # This is my callback function.
    print("The interrupt occurred, and returned {}".format(data))
    data[0] += 1

value = [0]
interrupt_enable_callback(my_function, value)
```

In this example *my_function()* will be called when the interrupt occurs, and the list *value* will be passed as the *user_data*. Inside the callback it will be received as *data*, but will still be the same object so any changes made

will be present in the original *value*. Every time the interrupt occurs *value[0]* will be incremented and a higher number will be printed.

An integer was not used for *value* because integers are immutable in Python so the original *value* would never change.

The callback may be disabled with `interrupt_callback_disable()`.

This function only applies when using devices that can generate an interrupt:

- MCC 152

Parameters

- **callback** (*callback function*) – The callback function.
- **user_data** (*object*) – callback function.

Raises

Exception – Internal error enabling the callback.

`daqhats.interrupt_callback_disable()`

Disable interrupt callbacks.

Raises

Exception – Internal error disabling the callback.

5.1.2 Data

5.1.2.1 Hat IDs

```
class daqhats.HatIDs(value, names=None, *, module=None, qualname=None, type=None, start=1,
                    boundary=None)
```

Known MCC HAT IDs.

ANY = 0

Match any MCC ID in `hat_list()`

MCC_118 = 322

MCC 118 ID

MCC_128 = 326

MCC 128 ID

MCC_134 = 323

MCC 134 ID

MCC_152 = 324

MCC 152 ID

MCC_172 = 325

MCC 172 ID

5.1.2.2 Trigger modes

```
class daqhats.TriggerModes(value, names=None, *, module=None, qualname=None, type=None, start=1, boundary=None)
```

Scan trigger input modes.

RISING_EDGE = 0

Start the scan on a rising edge of TRIG.

FALLING_EDGE = 1

Start the scan on a falling edge of TRIG.

ACTIVE_HIGH = 2

Start the scan any time TRIG is high.

ACTIVE_LOW = 3

Start the scan any time TRIG is low.

5.1.2.3 Scan / read option flags

```
class daqhats.OptionFlags(value, names=None, *, module=None, qualname=None, type=None, start=1, boundary=None)
```

Scan / read option flags. See individual methods for detailed descriptions.

DEFAULT = 0

Use default behavior.

NOSCALEDATA = 1

Read / write unscaled data.

NOCALIBRATEDATA = 2

Read / write uncalibrated data.

EXTCLOCK = 4

Use an external clock source.

EXTTRIGGER = 8

Use an external trigger source.

CONTINUOUS = 16

Run until explicitly stopped.

TEMPERATURE = 32

Return temperature (MCC 134)

5.1.3 HatError class

```
exception daqhats.HatError(address, value)
```

Exceptions raised for MCC DAQ HAT specific errors.

Parameters

- **address** (*int*) – the address of the board that caused the exception.
- **value** (*str*) – the exception description.

5.2 MCC 118 class

5.2.1 Methods

class `daqhats.mcc118(address=0)`

The class for an MCC 118 board.

Parameters

address (*int*) – board address, must be 0-7.

Raises

HatError – the board did not respond or was of an incorrect type

Methods

Method	Description
<code>mcc118.info()</code>	Get info about this device type.
<code>mcc118.firmware_version()</code>	Get the firmware version.
<code>mcc118.serial()</code>	Read the serial number.
<code>mcc118.blink_led()</code>	Blink the MCC 118 LED.
<code>mcc118.calibration_date()</code>	Read the calibration date.
<code>mcc118.calibration_coefficient_read()</code>	Read the calibration coefficients for a channel.
<code>mcc118.calibration_coefficient_write()</code>	Write the calibration coefficients for a channel.
<code>mcc118.trigger_mode()</code>	Set the external trigger input mode.
<code>mcc118.a_in_read()</code>	Read an analog input channel.
<code>mcc118.a_in_scan_actual_rate()</code>	Read the actual sample rate for a requested sample rate.
<code>mcc118.a_in_scan_start()</code>	Start a hardware-paced analog input scan.
<code>mcc118.a_in_scan_buffer_size()</code>	Read the size of the internal scan data buffer.
<code>mcc118.a_in_scan_read()</code>	Read scan status / data (list).
<code>mcc118.a_in_scan_read_numpy()</code>	Read scan status / data (NumPy array).
<code>mcc118.a_in_scan_channel_count()</code>	Get the number of channels in the current scan.
<code>mcc118.a_in_scan_stop()</code>	Stop the scan.
<code>mcc118.a_in_scan_cleanup()</code>	Free scan resources.
<code>mcc118.address()</code>	Read the board's address.

static info()

Return constant information about this type of device.

Returns

A namedtuple containing the following field names:

- **NUM_AI_CHANNELS** (*int*): The number of analog input channels (8.)
- **AI_MIN_CODE** (*int*): The minimum ADC code (0.)
- **AI_MAX_CODE** (*int*): The maximum ADC code (4095.)
- **AI_MIN_VOLTAGE** (*float*): The voltage corresponding to the minimum ADC code (-10.0.)
- **AI_MAX_VOLTAGE** (*float*): The voltage corresponding to the maximum ADC code (+10.0 - 1 LSB)

- **AI_MIN_RANGE** (float): The minimum voltage of the input range (-10.0.)
- **AI_MAX_RANGE** (float): The maximum voltage of the input range (+10.0.)

Return type
namedtuple

firmware_version()

Read the board firmware and bootloader versions.

Returns

A namedtuple containing the following field names:

- **version** (string): The firmware version, i.e “1.03”.
- **bootloader_version** (string): The bootloader version, i.e “1.01”.

Return type
namedtuple

Raises

HatError – the board is not initialized, does not respond, or responds incorrectly.

serial()

Read the serial number.

Returns

The serial number.

Return type

string

Raises

HatError – the board is not initialized, does not respond, or responds incorrectly.

blink_led(count)

Blink the MCC 118 LED.

Setting count to 0 will cause the LED to blink continuously until `blink_led()` is called again with a non-zero count.

Parameters

count (*int*) – The number of times to blink (max 255).

Raises

HatError – the board is not initialized, does not respond, or responds incorrectly.

calibration_date()

Read the calibration date.

Returns

The calibration date in the format “YYYY-MM-DD”.

Return type

string

Raises

HatError – the board is not initialized, does not respond, or responds incorrectly.

calibration_coefficient_read(channel)

Read the calibration coefficients for a single channel.

The coefficients are applied in the library as:

$$\text{calibrated_ADC_code} = (\text{raw_ADC_code} * \text{slope}) + \text{offset}$$
Parameters

channel (*int*) – The analog input channel (0-7.)

Returns

A namedtuple containing the following field names.

- **slope** (*float*): The slope.
- **offset** (*float*): The offset.

Return type

namedtuple

Raises

HatError – the board is not initialized, does not respond, or responds incorrectly.

calibration_coefficient_write(channel, slope, offset)

Temporarily write the calibration coefficients for a single channel.

The user can apply their own calibration coefficients by writing to these values. The values will reset to the factory values from the EEPROM whenever the class is initialized. This function will fail and raise a HatError exception if a scan is active when it is called.

The coefficients are applied in the library as:

$$\text{calibrated_ADC_code} = (\text{raw_ADC_code} * \text{slope}) + \text{offset}$$
Parameters

- **channel** (*int*) – The analog input channel (0-7.)
- **slope** (*float*) – The new slope value.
- **offset** (*float*) – The new offset value.

Raises

HatError – the board is not initialized, does not respond, or responds incorrectly.

trigger_mode(mode)

Set the external trigger input mode.

The available modes are:

- *TriggerModes.RISING_EDGE*: Start the scan when the TRIG input transitions from low to high.
- *TriggerModes.FALLING_EDGE*: Start the scan when the TRIG input transitions from high to low.
- *TriggerModes.ACTIVE_HIGH*: Start the scan when the TRIG input is high.
- *TriggerModes.ACTIVE_LOW*: Start the scan when the TRIG input is low.

Parameters

mode (*TriggerModes*) – The trigger mode.

Raises

HatError – the board is not initialized, does not respond, or responds incorrectly.

a_in_read(*channel*, *options*=*OptionFlags.DEFAULT*)

Perform a single reading of an analog input channel and return the value.

options is an ORed combination of *OptionFlags*. Valid flags for this method are:

- *OptionFlags.DEFAULT*: Return a calibrated voltage value. Any other flags will override *DEFAULT* behavior.
- *OptionFlags.NOSCALEDATA*: Return an ADC code (a value between 0 and 4095) rather than voltage.
- *OptionFlags.NOALIBRATEDATA*: Return data without the calibration factors applied.

Parameters

- **channel** (*int*) – The analog input channel number, 0-7.
- **options** (*int*) – ORed combination of *OptionFlags*, *OptionFlags.DEFAULT* if unspecified.

Returns

The read value.

Return type

float

Raises

- **HatError** – the board is not initialized, does not respond, or responds incorrectly.
- **ValueError** – the channel number is invalid.

a_in_scan_actual_rate(*channel_count*, *sample_rate_per_channel*)

Read the actual sample rate per channel for a requested sample rate.

The internal scan clock is generated from a 16 MHz clock source so only discrete frequency steps can be achieved. This function will return the actual rate for a requested channel count and rate setting.

This function does not perform any actions with a board, it simply calculates the rate.

Parameters

- **channel_count** (*int*) – The number of channels in the scan, 1-8.
- **sample_rate_per_channel** (*float*) – The desired per-channel rate of the internal sampling clock, max 100,000.0.

Returns

The actual sample rate.

Return type

float

Raises

ValueError – a scan argument is invalid.

a_in_scan_start(*channel_mask*, *samples_per_channel*, *sample_rate_per_channel*, *options*)

Start a hardware-paced analog input channel scan.

The scan runs as a separate thread from the user's code. This function will allocate a scan buffer and start the thread that reads data from the device into that buffer. The user reads the data from the scan buffer and the scan status using the *a_in_scan_read()* function. *a_in_scan_stop()* is used to stop a continuous scan, or to stop a finite scan before it completes. The user must call *a_in_scan_cleanup()* after the scan has finished and all desired data has been read; this frees all resources from the scan and allows additional scans to be performed.

The scan state has defined terminology:

- **Active:** `a_in_scan_start()` has been called and the device may be acquiring data or finished with the acquisition. The scan has not been cleaned up by calling `a_in_scan_cleanup()`, so another scan may not be started.
- **Running:** The scan is active and the device is still acquiring data. Certain methods like `a_in_read()` will return an error because the device is busy.

The scan options that may be used are:

- `OptionFlags.DEFAULT`: Return scaled and calibrated data, internal scan clock, no trigger, and finite operation. Any other flags will override DEFAULT behavior.
- `OptionFlags.NOSCALEDATA`: Return ADC codes (values between 0 and 4095) rather than voltage.
- `OptionFlags.NOCALIBRATEDATA`: Return data without the calibration factors applied.
- `OptionFlags.EXTCLOCK`: Use an external 3.3V or 5V logic signal at the CLK input as the scan clock. Multiple devices can be synchronized by connecting the CLK pins together and using this flag on all but one device so they will be clocked by the single device using its internal clock. `sample_rate_per_channel` is only used for buffer sizing.
- `OptionFlags.EXTRIGGER`: Hold off the scan (after calling `a_in_scan_start()`) until the trigger condition is met. The trigger is a 3.3V or 5V logic signal applied to the TRIG pin.
- `OptionFlags.CONTINUOUS`: Scans continuously until stopped by the user by calling `a_in_scan_stop()` and writes data to a circular buffer. The data must be read before being overwritten to avoid a buffer overrun error. `samples_per_channel` is only used for buffer sizing.

The scan buffer size will be allocated as follows:

Finite mode: Total number of samples in the scan.

Continuous mode: Either `samples_per_channel` or the value in the table below, whichever is greater.

Sample Rate	Buffer Size (per channel)
Not specified	10 kS
0-100 S/s	1 kS
100-10k S/s	10 kS
10k-100k S/s	100 kS

Specifying a very large value for `samples_per_channel` could use too much of the Raspberry Pi memory. If the memory allocation fails, the function will raise a `HatError` with this description. The allocation could succeed, but the lack of free memory could cause other problems in the Raspberry Pi. If you need to acquire a high number of samples then it is better to run the scan in continuous mode and stop it when you have acquired the desired amount of data. If a scan is active this method will raise a `HatError`.

Parameters

- `channel_mask` (*int*) – A bit mask of the desired channels (0x01 - 0xFF).
- `samples_per_channel` (*int*) – The number of samples to acquire per channel (finite mode,) or can be used to set a larger scan buffer size than the default value (continuous mode.)
- `sample_rate_per_channel` (*float*) – The per-channel rate of the internal scan clock, or the expected maximum rate of an external scan clock, max 100,000.0.
- `options` (*int*) – An ORed combination of `OptionFlags` flags that control the scan.

Raises

- ***HatError*** – a scan is active; memory could not be allocated; the board is not initialized, does not respond, or responds incorrectly.
- ***ValueError*** – a scan argument is invalid.

a_in_scan_buffer_size()

Read the internal scan data buffer size.

An internal data buffer is allocated for the scan when `a_in_scan_start()` is called. This function returns the total size of that buffer in samples.

Returns

The buffer size in samples.

Return type

int

Raises

HatError – the board is not initialized or no scan buffer is allocated (a scan is not active).

a_in_scan_status()

Read scan status and number of available samples per channel.

The analog input scan is started with `a_in_scan_start()` and runs in the background. This function reads the status of that background scan and the number of samples per channel available in the scan thread buffer.

Returns

A namedtuple containing the following field names:

- **running** (bool): True if the scan is running, False if it has stopped or completed.
- **hardware_overrun** (bool): True if the hardware could not acquire and unload samples fast enough and data was lost.
- **buffer_overrun** (bool): True if the background scan buffer was not read fast enough and data was lost.
- **triggered** (bool): True if the trigger conditions have been met and data acquisition started.
- **samples_available** (int): The number of samples per channel currently in the scan buffer.

Return type

namedtuple

Raises

HatError – A scan is not active, the board is not initialized, does not respond, or responds incorrectly.

a_in_scan_read(samples_per_channel, timeout)

Read scan status and data (as a list).

The analog input scan is started with `a_in_scan_start()` and runs in the background. This function reads the status of that background scan and optionally reads sampled data from the scan buffer.

Parameters

- **samples_per_channel** (*int*) – The number of samples per channel to read from the scan buffer. Specify a negative number to return all available samples immediately and ignore **timeout** or 0 to only read the scan status and return no data.
- **timeout** (*float*) – The amount of time in seconds to wait for the samples to be read. Specify a negative number to wait indefinitely, or 0 to return immediately with the samples that

are already in the scan buffer (up to **samples_per_channel**.) If the timeout is met and the specified number of samples have not been read, then the function will return all the available samples and the timeout status set.

Returns

A namedtuple containing the following field names:

- **running** (bool): True if the scan is running, False if it has stopped or completed.
- **hardware_overrun** (bool): True if the hardware could not acquire and unload samples fast enough and data was lost.
- **buffer_overrun** (bool): True if the background scan buffer was not read fast enough and data was lost.
- **triggered** (bool): True if the trigger conditions have been met and data acquisition started.
- **timeout** (bool): True if the timeout time expired before the specified number of samples were read.
- **data** (list of float): The data that was read from the scan buffer.

Return type

namedtuple

Raises

- **HatError** – A scan is not active, the board is not initialized, does not respond, or responds incorrectly.
- **ValueError** – Incorrect argument.

a_in_scan_read_numpy(*samples_per_channel*, *timeout*)

Read scan status and data (as a NumPy array).

This function is similar to [a_in_scan_read\(\)](#) except that the *data* key in the returned namedtuple is a NumPy array of float64 values and may be used directly with NumPy functions.

Parameters

- **samples_per_channel** (*int*) – The number of samples per channel to read from the scan buffer. Specify a negative number to read all available samples or 0 to only read the scan status and return no data.
- **timeout** (*float*) – The amount of time in seconds to wait for the samples to be read. Specify a negative number to wait indefinitely, or 0 to return immediately with the samples that are already in the scan buffer. If the timeout is met and the specified number of samples have not been read, then the function will return with the amount that has been read and the timeout status set.

Returns

A namedtuple containing the following field names:

- **running** (bool): True if the scan is running, False if it has stopped or completed.
- **hardware_overrun** (bool): True if the hardware could not acquire and unload samples fast enough and data was lost.
- **buffer_overrun** (bool): True if the background scan buffer was not read fast enough and data was lost.
- **triggered** (bool): True if the trigger conditions have been met and data acquisition started.

- **timeout** (bool): True if the timeout time expired before the specified number of samples were read.
- **data** (NumPy array of float64): The data that was read from the scan buffer.

Return type
namedtuple

Raises

- ***HatError*** – A scan is not active, the board is not initialized, does not respond, or responds incorrectly.
- **ValueError** – Incorrect argument.

a_in_scan_channel_count()

Read the number of channels in the current analog input scan.

Returns
The number of channels (0 if no scan is active, 1-8 otherwise.)

Return type
int

Raises

HatError – the board is not initialized, does not respond, or responds incorrectly.

a_in_scan_stop()

Stops an analog input scan.

The device stops acquiring data immediately. The scan data that has been read into the scan buffer is available until [a_in_scan_cleanup\(\)](#) is called.

Raises

HatError – the board is not initialized, does not respond, or responds incorrectly.

a_in_scan_cleanup()

Free analog input scan resources after the scan is complete.

This will free the scan buffer and other resources used by the background scan and make it possible to start another scan with [a_in_scan_start\(\)](#).

Raises

HatError – the board is not initialized, does not respond, or responds incorrectly.

address()

Return the device address.

5.3 MCC 128 class

5.3.1 Methods

class `daqhats.mcc128(address=0)`

The class for an MCC 128 board.

Parameters

address (*int*) – board address, must be 0-7.

Raises

HatError – the board did not respond or was of an incorrect type

Methods

Method	Description
<code>mcc128.info()</code>	Get info about this device type.
<code>mcc128.firmware_version()</code>	Get the firmware version.
<code>mcc128.serial()</code>	Read the serial number.
<code>mcc128.blink_led()</code>	Blink the MCC 128 LED.
<code>mcc128.calibration_date()</code>	Read the calibration date.
<code>mcc128.calibration_coefficient_read()</code>	Read the calibration coefficients for a mode/range.
<code>mcc128.calibration_coefficient_write()</code>	Write the calibration coefficients for a mode/range.
<code>mcc128.trigger_mode()</code>	Set the external trigger input mode.
<code>mcc128.a_in_mode_read()</code>	Read the analog input mode.
<code>mcc128.a_in_mode_write()</code>	Write the analog input mode.
<code>mcc128.a_in_range_read()</code>	Read the analog input range.
<code>mcc128.a_in_range_write()</code>	Write the analog input range.
<code>mcc128.a_in_read()</code>	Read an analog input channel.
<code>mcc128.a_in_scan_actual_rate()</code>	Read the actual sample rate for a requested sample rate.
<code>mcc128.a_in_scan_start()</code>	Start a hardware-paced analog input scan.
<code>mcc128.a_in_scan_buffer_size()</code>	Read the size of the internal scan data buffer.
<code>mcc128.a_in_scan_read()</code>	Read scan status / data (list).
<code>mcc128.a_in_scan_read_numpy()</code>	Read scan status / data (NumPy array).
<code>mcc128.a_in_scan_channel_count()</code>	Get the number of channels in the current scan.
<code>mcc128.a_in_scan_stop()</code>	Stop the scan.
<code>mcc128.a_in_scan_cleanup()</code>	Free scan resources.
<code>mcc128.address()</code>	Read the board's address.

static info()

Return constant information about this type of device.

Returns

A namedtuple containing the following field names:

- **NUM_AI_MODES** (int): The number of analog input modes (2.)
- **NUM_AI_CHANNELS** (list of int): The number of analog input channels for each mode (8, 4.)
- **AI_MIN_CODE** (int): The minimum ADC code (0.)
- **AI_MAX_CODE** (int): The maximum ADC code (65535.)
- **NUM_AI_RANGES** (int): The number of analog input ranges (4.)
- **AI_MIN_VOLTAGE** (list of float): The voltage corresponding to the minimum ADC code for each range (-10.0, -5.0, -2.0, -1.0.)
- **AI_MAX_VOLTAGE** (list of float): The voltage corresponding to the maximum ADC code for each range (+10.0 - 1 LSB, +5.0 - 1 LSB, +2.0 - 1 LSB, +1.0 - 1 LSB.)
- **AI_MIN_RANGE** (list of float): The minimum voltage of the input range for each range (-10.0, -5.0, -2.0, -1.0.)
- **AI_MAX_RANGE** (list of float): The maximum voltage of the input range for each range (+10.0, +5.0, +2.0, +1.0.)

Return type
namedtuple

firmware_version()

Read the board firmware version.

Returns

A namedtuple containing the following field names:

- **version** (string): The firmware version, i.e “1.03”.

Return type
namedtuple

Raises

HatError – the board is not initialized, does not respond, or responds incorrectly.

serial()

Read the serial number.

Returns
The serial number.

Return type
string

Raises

HatError – the board is not initialized, does not respond, or responds incorrectly.

blink_led(count)

Blink the MCC 128 LED.

Setting count to 0 will cause the LED to blink continuously until `blink_led()` is called again with a non-zero count.

Parameters
count (*int*) – The number of times to blink (max 255).

Raises

HatError – the board is not initialized, does not respond, or responds incorrectly.

calibration_date()

Read the calibration date.

Returns
The calibration date in the format “YYYY-MM-DD”.

Return type
string

Raises

HatError – the board is not initialized, does not respond, or responds incorrectly.

calibration_coefficient_read(a_in_range)

Read the calibration coefficients for a specified input range.

The coefficients are applied in the library as:

```
calibrated_ADC_code = (raw_ADC_code * slope) + offset
```

Parameters

a_in_range (*AnalogInputRange*) – The input range.

Returns

A namedtuple containing the following field names:

- **slope** (float): The slope.
- **offset** (float): The offset.

Return type

namedtuple

Raises

HatError – the board is not initialized, does not respond, or responds incorrectly.

calibration_coefficient_write(*a_in_range*, *slope*, *offset*)

Temporarily write the calibration coefficients for a specified input range.

The user can apply their own calibration coefficients by writing to these values. The values will reset to the factory values from the EEPROM whenever the class is initialized. This function will fail and raise a HatError exception if a scan is active when it is called.

The coefficients are applied in the library as:

```
calibrated_ADC_code = (raw_ADC_code * slope) + offset
```

Parameters

- **a_in_range** (*AnalogInputRange*) – The input range.
- **slope** (*float*) – The new slope value.
- **offset** (*float*) – The new offset value.

Raises

HatError – the board is not initialized, does not respond, or responds incorrectly.

trigger_mode(*mode*)

Set the external trigger input mode.

The available modes are:

- *TriggerModes.RISING_EDGE*: Start the scan when the TRIG input transitions from low to high.
- *TriggerModes.FALLING_EDGE*: Start the scan when the TRIG input transitions from high to low.
- *TriggerModes.ACTIVE_HIGH*: Start the scan when the TRIG input is high.
- *TriggerModes.ACTIVE_LOW*: Start the scan when the TRIG input is low.

Parameters

mode (*TriggerModes*) – The trigger mode.

Raises

HatError – the board is not initialized, does not respond, or responds incorrectly.

a_in_mode_write(*a_in_mode*)

This sets the analog input mode to one of the valid values:

- *AnalogInputMode.SE*: Single-ended (8 inputs relative to ground.)
- *AnalogInputMode.DIFF*: Differential (4 channels with positive and negative inputs.)

Parameters

a_in_mode (*AnalogInputMode*) – The input mode.

Raises

HatError – the board is not initialized, does not respond, or responds incorrectly.

a_in_mode_read()

Read the analog input mode.

Reads the current analog input mode.

Returns

The current analog input mode.

Return type

AnalogInputMode

Raises

HatError – the board is not initialized, does not respond, or responds incorrectly.

a_in_range_write(a_in_range)

This sets the analog input range to one of the valid values:

- *AnalogInputRange.BIP_10V*: +/- 10V range
- *AnalogInputRange.BIP_5V*: +/- 5V range
- *AnalogInputRange.BIP_2V*: +/- 2V range
- *AnalogInputRange.BIP_1V*: +/- 1V range

Parameters

a_in_range (*AnalogInputRange*) – The input range.

Raises

HatError – the board is not initialized, does not respond, or responds incorrectly.

a_in_range_read()

Read the analog input range.

Reads the current analog input range.

Returns

The current analog input range.

Return type

AnalogInputRange

Raises

HatError – the board is not initialized, does not respond, or responds incorrectly.

a_in_read(channel, options=OptionFlags.DEFAULT)

Perform a single reading of an analog input channel and return the value.

options is an ORed combination of OptionFlags. Valid flags for this method are:

- *OptionFlags.DEFAULT*: Return a calibrated voltage value. Any other flags will override DEFAULT behavior.
- *OptionFlags.NOSCALEDATA*: Return an ADC code (a value between 0 and 65535) rather than voltage.
- *OptionFlags.NOCALIBRATEDATA*: Return data without the calibration factors applied.

Parameters

- **channel** (*int*) – The analog input channel number, 0-7.
- **options** (*int*) – ORed combination of *OptionFlags*, *OptionFlags.DEFAULT* if unspecified.

Returns

The read value.

Return type

float

Raises

HatError – the board is not initialized, does not respond, or responds incorrectly.

a_in_scan_actual_rate(*channel_count*, *sample_rate_per_channel*)

Read the actual sample rate per channel for a requested sample rate.

The internal scan clock is generated from a 16 MHz clock source so only discrete frequency steps can be achieved. This function will return the actual rate for a requested channel count and rate setting.

This function does not perform any actions with a board, it simply calculates the rate.

Parameters

- **channel_count** (*int*) – The number of channels in the scan, 1-8.
- **sample_rate_per_channel** (*float*) – The desired per-channel rate of the internal sampling clock, max 100,000.0.

Returns

The actual sample rate.

Return type

float

Raises

ValueError – a scan argument is invalid.

a_in_scan_start(*channel_mask*, *samples_per_channel*, *sample_rate_per_channel*, *options*)

Start a hardware-paced analog input channel scan.

The scan runs as a separate thread from the user's code. This function will allocate a scan buffer and start the thread that reads data from the device into that buffer. The user reads the data from the scan buffer and the scan status using the *a_in_scan_read()* function. *a_in_scan_stop()* is used to stop a continuous scan, or to stop a finite scan before it completes. The user must call *a_in_scan_cleanup()* after the scan has finished and all desired data has been read; this frees all resources from the scan and allows additional scans to be performed.

The scan state has defined terminology:

- **Active:** *a_in_scan_start()* has been called and the device may be acquiring data or finished with the acquisition. The scan has not been cleaned up by calling *a_in_scan_cleanup()*, so another scan may not be started.
- **Running:** The scan is active and the device is still acquiring data. Certain methods like *a_in_read()* will return an error because the device is busy.

The scan options that may be used are:

- *OptionFlags.DEFAULT*: Return scaled and calibrated data, internal scan clock, no trigger, and finite operation. Any other flags will override DEFAULT behavior.

- *OptionFlags.NOSCALEDATA*: Return ADC codes (values between 0 and 65535) rather than voltage.
- *OptionFlags.NOCALIBRATEDATA*: Return data without the calibration factors applied.
- *OptionFlags.EXTCLOCK*: Use an external 3.3V or 5V logic signal at the CLK input as the scan clock. Multiple devices can be synchronized by connecting the CLK pins together and using this flag on all but one device so they will be clocked by the single device using its internal clock. **sample_rate_per_channel** is only used for buffer sizing.
- *OptionFlags.EXTTRIGGER*: Hold off the scan (after calling *a_in_scan_start()*) until the trigger condition is met. The trigger is a 3.3V or 5V logic signal applied to the TRIG pin.
- *OptionFlags.CONTINUOUS*: Scans continuously until stopped by the user by calling *a_in_scan_stop()* and writes data to a circular buffer. The data must be read before being overwritten to avoid a buffer overrun error. **samples_per_channel** is only used for buffer sizing.

The scan buffer size will be allocated as follows:

Finite mode: Total number of samples in the scan.

Continuous mode: Either **samples_per_channel** or the value in the table below, whichever is greater.

Sample Rate	Buffer Size (per channel)
Not specified	10 kS
0-100 S/s	1 kS
100-10k S/s	10 kS
10k-100k S/s	100 kS

Specifying a very large value for **samples_per_channel** could use too much of the Raspberry Pi memory. If the memory allocation fails, the function will raise a *HatError* with this description. The allocation could succeed, but the lack of free memory could cause other problems in the Raspberry Pi. If you need to acquire a high number of samples then it is better to run the scan in continuous mode and stop it when you have acquired the desired amount of data. If a scan is active this method will raise a *HatError*.

Parameters

- **channel_mask** (*int*) – A bit mask of the desired channels (0x01 - 0xFF).
- **samples_per_channel** (*int*) – The number of samples to acquire per channel (finite mode,) or or can be used to set a larger scan buffer size than the default value (continuous mode.)
- **sample_rate_per_channel** (*float*) – The per-channel rate of the internal scan clock, or the expected maximum rate of an external scan clock, max 100,000.0.
- **options** (*int*) – An ORed combination of *OptionFlags* flags that control the scan.

Raises

- *HatError* – a scan is active; memory could not be allocated; the board is not initialized, does not respond, or responds incorrectly.
- *ValueError* – a scan argument is invalid.

a_in_scan_buffer_size()

Read the internal scan data buffer size.

An internal data buffer is allocated for the scan when *a_in_scan_start()* is called. This function returns the total size of that buffer in samples.

Returns

The buffer size in samples.

Return type

int

Raises*HatError* – the board is not initialized or no scan buffer is allocated (a scan is not active).**a_in_scan_status()**

Read scan status and number of available samples per channel.

The analog input scan is started with *a_in_scan_start()* and runs in the background. This function reads the status of that background scan and the number of samples per channel available in the scan thread buffer.

Returns

A namedtuple containing the following field names:

- **running** (bool): True if the scan is running, False if it has stopped or completed.
- **hardware_overrun** (bool): True if the hardware could not acquire and unload samples fast enough and data was lost.
- **buffer_overrun** (bool): True if the background scan buffer was not read fast enough and data was lost.
- **triggered** (bool): True if the trigger conditions have been met and data acquisition started.
- **samples_available** (int): The number of samples per channel currently in the scan buffer.

Return type

namedtuple

Raises*HatError* – A scan is not active, the board is not initialized, does not respond, or responds incorrectly.**a_in_scan_read(samples_per_channel, timeout)**

Read scan status and data (as a list).

The analog input scan is started with *a_in_scan_start()* and runs in the background. This function reads the status of that background scan and optionally reads sampled data from the scan buffer.

Parameters

- **samples_per_channel** (*int*) – The number of samples per channel to read from the scan buffer. Specify a negative number to return all available samples immediately and ignore **timeout** or 0 to only read the scan status and return no data.
- **timeout** (*float*) – The amount of time in seconds to wait for the samples to be read. Specify a negative number to wait indefinitely, or 0 to return immediately with the samples that are already in the scan buffer (up to **samples_per_channel**.) If the timeout is met and the specified number of samples have not been read, then the function will return all the available samples and the timeout status set.

Returns

A namedtuple containing the following field names:

- **running** (bool): True if the scan is running, False if it has stopped or completed.
- **hardware_overrun** (bool): True if the hardware could not acquire and unload samples fast enough and data was lost.

- **buffer_overflow** (bool): True if the background scan buffer was not read fast enough and data was lost.
- **triggered** (bool): True if the trigger conditions have been met and data acquisition started.
- **timeout** (bool): True if the timeout time expired before the specified number of samples were read.
- **data** (list of float): The data that was read from the scan buffer.

Return type

namedtuple

Raises

- **HatError** – A scan is not active, the board is not initialized, does not respond, or responds incorrectly.
- **ValueError** – Incorrect argument.

a_in_scan_read_numpy(*samples_per_channel*, *timeout*)

Read scan status and data (as a NumPy array).

This function is similar to `a_in_scan_read()` except that the *data* key in the returned namedtuple is a NumPy array of float64 values and may be used directly with NumPy functions.

Parameters

- **samples_per_channel** (*int*) – The number of samples per channel to read from the scan buffer. Specify a negative number to read all available samples or 0 to only read the scan status and return no data.
- **timeout** (*float*) – The amount of time in seconds to wait for the samples to be read. Specify a negative number to wait indefinitely, or 0 to return immediately with the samples that are already in the scan buffer. If the timeout is met and the specified number of samples have not been read, then the function will return with the amount that has been read and the timeout status set.

Returns

A namedtuple containing the following field names:

- **running** (bool): True if the scan is running, False if it has stopped or completed.
- **hardware_overflow** (bool): True if the hardware could not acquire and unload samples fast enough and data was lost.
- **buffer_overflow** (bool): True if the background scan buffer was not read fast enough and data was lost.
- **triggered** (bool): True if the trigger conditions have been met and data acquisition started.
- **timeout** (bool): True if the timeout time expired before the specified number of samples were read.
- **data** (NumPy array of float64): The data that was read from the scan buffer.

Return type

namedtuple

Raises

- **HatError** – A scan is not active, the board is not initialized, does not respond, or responds incorrectly.
- **ValueError** – Incorrect argument.

a_in_scan_channel_count()

Read the number of channels in the current analog input scan.

Returns

The number of channels (0 if no scan is active, 1-8 otherwise.)

Return type

int

Raises

HatError – the board is not initialized, does not respond, or responds incorrectly.

a_in_scan_stop()

Stops an analog input scan.

The device stops acquiring data immediately. The scan data that has been read into the scan buffer is available until *a_in_scan_cleanup()* is called.

Raises

HatError – the board is not initialized, does not respond, or responds incorrectly.

a_in_scan_cleanup()

Free analog input scan resources after the scan is complete.

This will free the scan buffer and other resources used by the background scan and make it possible to start another scan with *a_in_scan_start()*.

Raises

HatError – the board is not initialized, does not respond, or responds incorrectly.

address()

Return the device address.

5.3.2 Data

5.3.2.1 Analog input modes

```
class daqhats.AnalogInputMode(value, names=None, *, module=None, qualname=None, type=None, start=1,
                               boundary=None)
```

Analog input modes.

SE = 0

Single-ended mode.

DIFF = 1

Differential mode.

5.3.2.2 Analog input ranges

```
class daqhats.AnalogInputRange(value, names=None, *, module=None, qualname=None, type=None,
                                 start=1, boundary=None)
```

Analog input ranges.

BIP_10V = 0

+/- 10V input range.

BIP_5V = 1
+/- 5V input range.

BIP_2V = 2
+/- 2V input range.

BIP_1V = 3
+/- 1V input range

5.4 MCC 134 class

5.4.1 Methods

class `daqhats.mcc134(address=0)`

The class for an MCC 134 board.

Parameters

address (*int*) – board address, must be 0-7.

Raises

HatError – the board did not respond or was of an incorrect type

Methods

Method	Description
<code>mcc134.info()</code>	Get info about this device type.
<code>mcc134.serial()</code>	Read the serial number.
<code>mcc134.calibration_date()</code>	Read the calibration date.
<code>mcc134.calibration_coefficient_read()</code>	Read the calibration coefficients for a channel.
<code>mcc134.calibration_coefficient_write()</code>	Write the calibration coefficients for a channel.
<code>mcc134.tc_type_write()</code>	Write the thermocouple type for a channel.
<code>mcc134.tc_type_read()</code>	Read the thermocouple type for a channel.
<code>mcc134.update_interval_write()</code>	Write the temperature update interval.
<code>mcc134.update_interval_read()</code>	Read the temperature update interval.
<code>mcc134.t_in_read()</code>	Read a temperature input channel.
<code>mcc134.a_in_read()</code>	Read an analog input channel.
<code>mcc134.cjc_read()</code>	Read a CJC temperature
<code>mcc134.address()</code>	Read the board's address.

OPEN_TC_VALUE = -9999.0

Return value for an open thermocouple.

OVERRANGE_TC_VALUE = -8888.0

Return value for thermocouple voltage outside the valid range.

COMMON_MODE_TC_VALUE = -7777.0

Return value for thermocouple input outside the common-mode range.

static info()

Return constant information about this type of device.

Returns

A namedtuple containing the following field names:

- **NUM_AI_CHANNELS** (int): The number of analog input channels (4.)
- **AI_MIN_CODE** (int): The minimum ADC code (-8,388,608.)
- **AI_MAX_CODE** (int): The maximum ADC code (8,388,607.)
- **AI_MIN_VOLTAGE** (float): The voltage corresponding to the minimum ADC code (-0.078125.)
- **AI_MAX_VOLTAGE** (float): The voltage corresponding to the maximum ADC code (+0.078125 - 1 LSB)
- **AI_MIN_RANGE** (float): The minimum voltage of the input range (-0.078125.)
- **AI_MAX_RANGE** (float): The maximum voltage of the input range (+0.078125.)

Return type

namedtuple

serial()

Read the serial number.

Returns

The serial number.

Return type

string

Raises

HatError – the board is not initialized, does not respond, or responds incorrectly.

calibration_date()

Read the calibration date.

Returns

The calibration date in the format “YYYY-MM-DD”.

Return type

string

Raises

HatError – the board is not initialized, does not respond, or responds incorrectly.

calibration_coefficient_read(channel)

Read the calibration coefficients for a single channel.

The coefficients are applied in the library as:

```
calibrated_ADC_code = (raw_ADC_code * slope) + offset
```

Parameters

channel (*int*) – The thermocouple channel (0-3.)

Returns

A namedtuple containing the following field names:

- **slope** (float): The slope.
- **offset** (float): The offset.

Return type

namedtuple

Raises*HatError* – the board is not initialized, does not respond, or responds incorrectly.**calibration_coefficient_write**(*channel*, *slope*, *offset*)

Temporarily write the calibration coefficients for a single channel.

The user can apply their own calibration coefficients by writing to these values. The values will reset to the factory values from the EEPROM whenever the class is initialized.

The coefficients are applied in the library as:

```
calibrated_ADC_code = (raw_ADC_code * slope) + offset
```

Parameters

- **channel** (*int*) – The thermocouple channel (0-3.)
- **slope** (*float*) – The new slope value.
- **offset** (*float*) – The new offset value.

Raises*HatError* – the board is not initialized, does not respond, or responds incorrectly.**tc_type_write**(*channel*, *tc_type*)

Write the thermocouple type for a channel.

Enables a channel and tells the library what thermocouple type is connected to the channel. This is needed for correct temperature calculations. The type is one of *TcTypes* and the board will default to all channels disabled (set to *TcTypes.DISABLED*) when it is first opened.**Parameters**

- **channel** (*int*) – The analog input channel number, 0-3.
- **tc_type** (*TcTypes*) – The thermocouple type.

Raises*HatError* – the board is not initialized, does not respond, or responds incorrectly.**tc_type_read**(*channel*)

Read the thermocouple type for a channel.

Reads the current thermocouple type for the specified channel. The type is one of *TcTypes* and the board will default to all channels disabled (set to *TcTypes.DISABLED*) when it is first opened.**Parameters****channel** (*int*) – The analog input channel number, 0-3.**Returns**

int: The thermocouple type.

Raises*HatError* – the board is not initialized, does not respond, or responds incorrectly.

update_interval_write(interval)

Write the temperature update interval.

Tells the MCC 134 library how often to update temperatures, with the interval specified in seconds. The library defaults to updating every second, but you may increase this interval if you do not plan to call `t_in_read()` very often. This will reduce the load on shared resources for other DAQ HATs.

Parameters

interval (*int*) – The interval in seconds, 1 - 255.

Raises

HatError – the board is not initialized, does not respond, or responds incorrectly.

update_interval_read()

Read the temperature update interval.

Reads the library temperature update rate in seconds.

Returns

int: The update interval.

Raises

HatError – the board is not initialized, does not respond, or responds incorrectly.

t_in_read(channel)

Read a thermocouple input channel temperature.

The channel must be enabled with `tc_type_write()` or the method will raise a `ValueError` exception.

This method returns immediately with the most recent temperature reading for the specified channel. When a board is open, the library will read each channel approximately once per second. There will be a delay when the board is first opened because the read thread has to read the cold junction compensation sensors and thermocouple inputs before it can return the first value.

The method returns the value as degrees Celsius. The temperature value can have some special values for abnormal conditions:

- `mcc134.OPEN_TC_VALUE` if an open thermocouple is detected.
- `mcc134.OVERRANGE_TC_VALUE` if a value outside valid thermocouple voltage is detected.
- `mcc134.COMMON_MODE_TC_VALUE` if a common-mode voltage error is detected. This occurs when thermocouples on the same MCC 134 are at different voltages.

Parameters

channel (*int*) – The analog input channel number, 0-3.

Returns

The thermocouple temperature.

Return type

float

Raises

- **HatError** – the board is not initialized, does not respond, or responds incorrectly.
- **ValueError** – the channel number is invalid or the channel is disabled.

a_in_read(*channel*, *options*=*OptionFlags.DEFAULT*)

Read an analog input channel and return the value.

The channel must be enabled with *tc_type_write()* or the method will raise a *ValueError* exception.

The returned voltage can have a special value to indicate abnormal conditions:

- *mcc134.COMMON_MODE_TC_VALUE* if a common-mode voltage error is detected. This occurs when thermocouples on the same MCC 134 are at different voltages.

options is an ORed combination of *OptionFlags*. Valid flags for this method are:

- *OptionFlags.DEFAULT*: Return a calibrated voltage value. Any other flags will override *DEFAULT* behavior.
- *OptionFlags.NOSCALEDATA*: Return an ADC code (a value between -8,388,608 and 8,388,607) rather than voltage.
- *OptionFlags.NOALIBRATEDATA*: Return data without the calibration factors applied.

Parameters

- **channel** (*int*) – The analog input channel number, 0-3.
- **options** (*int*) – ORed combination of *OptionFlags*, *OptionFlags.DEFAULT* if unspecified.

Returns

The read value.

Return type

float

Raises

- ***HatError*** – the board is not initialized, does not respond, or responds incorrectly.
- ***ValueError*** – the channel number is invalid.

cjc_read(*channel*)

Read the cold junction compensation temperature for a specified channel.

Reads the cold junction sensor temperature for the specified thermocouple terminal. The library automatically performs cold junction compensation, so this function is only needed for informational use or if you want to perform your own compensation. The temperature is returned in degrees C.

Parameters

channel (*int*) – The analog input channel number, 0-3.

Returns

The read value.

Return type

float

Raises

- ***HatError*** – the board is not initialized, does not respond, or responds incorrectly.
- ***ValueError*** – the channel number is invalid.

address()

Return the device address.

5.4.2 Data

5.4.2.1 Thermocouple types

class `daqhats.TcTypes`(*value, names=None, *, module=None, qualname=None, type=None, start=1, boundary=None*)

Thermocouple types.

TYPE_J = 0

Type J

TYPE_K = 1

Type K

TYPE_T = 2

Type T

TYPE_E = 3

Type E

TYPE_R = 4

Type R

TYPE_S = 5

Type S

TYPE_B = 6

Type B

TYPE_N = 7

Type N

DISABLED = 255

Disabled

5.5 MCC 152 class

5.5.1 Methods

class `daqhats.mcc152`(*address=0*)

The class for an MCC 152 board.

Parameters

address (*int*) – board address, must be 0-7.

Raises

HatError – the board did not respond or was of an incorrect type

Methods

Method	Description
<code>mcc152.info()</code>	Get info about this device type.
<code>mcc152.serial()</code>	Read the serial number.
<code>mcc152.a_out_write()</code>	Write an analog output channel.
<code>mcc152.a_out_write_all()</code>	Write all analog output channels.
<code>mcc152.dio_reset()</code>	Reset the digital I/O to the default configuration.
<code>mcc152.dio_input_read_bit()</code>	Read a digital input.
<code>mcc152.dio_input_read_port()</code>	Read all digital inputs.
<code>mcc152.dio_input_read_tuple()</code>	Read all digital inputs as a tuple.
<code>mcc152.dio_output_write_bit()</code>	Write a digital output.
<code>mcc152.dio_output_write_port()</code>	Write all digital outputs.
<code>mcc152.dio_output_write_dict()</code>	Write multiple digital outputs with a dictionary.
<code>mcc152.dio_output_read_bit()</code>	Read the state of a digital output.
<code>mcc152.dio_output_read_port()</code>	Read the state of all digital outputs.
<code>mcc152.dio_output_read_tuple()</code>	Read the state of all digital outputs as a tuple.
<code>mcc152.dio_int_status_read_bit()</code>	Read the interrupt status for a single channel.
<code>mcc152.dio_int_status_read_port()</code>	Read the interrupt status for all channels.
<code>mcc152.dio_int_status_read_tuple()</code>	Read the interrupt status for all channels as a tuple.
<code>mcc152.dio_config_write_bit()</code>	Write a digital I/O configuration item value for a single channel.
<code>mcc152.dio_config_write_port()</code>	Write a digital I/O configuration item value for all channels.
<code>mcc152.dio_config_write_dict()</code>	Write a digital I/O configuration item value for multiple channels.
<code>mcc152.dio_config_read_bit()</code>	Read a digital I/O configuration item value for a single channel.
<code>mcc152.dio_config_read_port()</code>	Read a digital I/O configuration item value for all channels.
<code>mcc152.dio_config_read_tuple()</code>	Read a digital I/O configuration item value for all channels as a tuple.
<code>mcc152.address()</code>	Read the board's address.

static info()

Return constant information about this type of device.

Returns

A namedtuple containing the following field names:

- **NUM_DIO_CHANNELS** (int): The number of digital I/O channels (8.)
- **NUM_AO_CHANNELS** (int): The number of analog output channels (2.)
- **AO_MIN_CODE** (int): The minimum DAC code (0.)
- **AO_MAX_CODE** (int): The maximum DAC code (4095.)
- **AO_MIN_VOLTAGE** (float): The voltage corresponding to the minimum DAC code (0.0.)
- **AO_MAX_VOLTAGE** (float): The voltage corresponding to the maximum DAC code (+5.0 - 1 LSB)
- **AO_MIN_RANGE** (float): The minimum voltage of the output range (0.0.)

- **AO_MAX_RANGE** (float): The maximum voltage of the output range (+5.0.)

Return type

namedtuple

serial()

Read the serial number.

Returns

The serial number.

Return type

string

Raises**HatError** – the board is not initialized, does not respond, or responds incorrectly.**a_out_write(channel, value, options=OptionFlags.DEFAULT)**

Write a single analog output channel value. The value will be limited to the range of the DAC without raising an exception.

options is an OptionFlags value. Valid flags for this method are:

- **OptionFlags.DEFAULT**: Write a voltage value (0 - 5).
- **OptionFlags.NOSCALEDATA**: Write a DAC code (a value between 0 and 4095) rather than voltage.

Parameters

- **channel** (*int*) – The analog output channel number, 0-1.
- **value** (*float*) – The value to write.
- **options** (*int*) – An **OptionFlags** value, **OptionFlags.DEFAULT** if unspecified.

Raises

- **HatError** – the board is not initialized, does not respond, or responds incorrectly.
- **ValueError** – an argument is invalid.

a_out_write_all(values, options=OptionFlags.DEFAULT)

Write all analog output channels simultaneously.

options is an OptionFlags value. Valid flags for this method are:

- **OptionFlags.DEFAULT**: Write voltage values (0 - 5).
- **OptionFlags.NOSCALEDATA**: Write DAC codes (values between 0 and 4095) rather than voltage.

Parameters

- **values** (*list of float*) – The values to write, in channel order. There must be at least two values, but only the first two will be used.
- **options** (*int*) – An **OptionFlags** value, **OptionFlags.DEFAULT** if unspecified.

Raises

- **HatError** – the board is not initialized, does not respond, or responds incorrectly.
- **ValueError** – an argument is invalid.

dio_reset()

Reset the DIO to the default configuration.

- All channels input
- Output registers set to 1
- Input inversion disabled
- No input latching
- Pull-up resistors enabled
- All interrupts disabled
- Push-pull output type

Raises

HatError – the board is not initialized, does not respond, or responds incorrectly.

dio_input_read_bit(channel)

Read a single digital input channel.

Returns 0 if the input is low, 1 if it is high.

If the specified channel is configured as an output this will return the value present at the terminal.

This method reads the entire input register even though a single channel is specified, so care must be taken when latched inputs are enabled. If a latched input changes between input reads then changes back to its original value, the next input read will report the change to the first value then the following read will show the original value. If another input is read then this input change could be missed so it is best to use [dio_input_read_port\(\)](#) or [dio_input_read_tuple\(\)](#) when using latched inputs.

Parameters

channel (*int*) – The DIO channel number, 0-7.

Returns

The input value.

Return type

int

Raises

- ***HatError*** – the board is not initialized, does not respond, or responds incorrectly.
- ***ValueError*** – an argument is invalid.

dio_input_read_port()

Read all digital input channels.

Returns the values as an integer with a value of 0 - 255. Each channel is represented by a bit in the integer (bit 0 is channel 0, etc.)

The value of a specific input can be found by examining the bit at that location. For example, to act on the channel 3 input:

```
inputs = mcc152.dio_input_read_port()
if (inputs & (1 << 3)) == 0:
    print("channel 3 is 0")
else:
    print("channel 3 is 1")
```

If a channel is configured as an output this will return the value present at the terminal.

Care must be taken when latched inputs are enabled. If a latched input changes between input reads then changes back to its original value, the next input read will report the change to the first value then the following read will show the original value.

Returns

int: The input values.

Raises

HatError – the board is not initialized, does not respond, or responds incorrectly.

`dio_input_read_tuple()`

Read all digital inputs at once as a tuple.

Returns a tuple of all input values in channel order. For example, to compare the channel 1 input to the channel 3 input:

```
inputs = mcc152.dio_input_read_tuple()
if inputs[1] == inputs[3]:
    print("channel 1 and channel 3 inputs are the same")
```

If a channel is configured as an output this will return the value present at the terminal.

Care must be taken when latched inputs are enabled. If a latched input changes between input reads then changes back to its original value, the next input read will report the change to the first value then the following read will show the original value.

Returns

tuple of int: The input values.

Raises

HatError – the board is not initialized, does not respond, or responds incorrectly.

`dio_output_write_bit(channel, value)`

Write a single digital output channel.

If the specified channel is configured as an input this will not have any effect at the terminal, but allows the output register to be loaded before configuring the channel as an output.

Parameters

- **channel** (*int*) – The digital channel number, 0-7.
- **value** (*int*) – The output value, 0 or 1.

Raises

- **HatError** – the board is not initialized, does not respond, or responds incorrectly.
- **ValueError** – an argument is invalid.

`dio_output_write_port(values)`

Write all digital output channel values.

Pass an integer in the range of 0 - 255, where each bit represents the value of the associated channel (bit 0 is channel 0, etc.) If a specified channel is configured as an input this will not have any effect at the terminal, but allows the output register to be loaded before configuring the channel as an output.

To change specific outputs without affecting other outputs first read the output values with `dio_output_read_port()`, change the desired bits in the result, then write them back.

For example, to set channels 0 and 2 to 1 without affecting the other outputs:

```
values = mcc152.dio_output_read_port()
values |= 0x05
mcc152.dio_output_write_port(values)
```

Parameters

values (*integer*) – The output values.

Raises

HatError – the board is not initialized, does not respond, or responds incorrectly.

dio_output_write_dict(*value_dict*)

Write multiple digital output channel values.

Pass a dictionary containing channel:value pairs. If a channel is repeated in the dictionary then the last value will be used. If a specified channel is configured as an input this will not have any effect at the terminal, but allows the output register to be loaded before configuring the channel as an output.

For example, to set channels 0 and 2 to 1 without affecting the other outputs:

```
values = { 0:1, 2:1 }
mcc152.dio_output_write_dict(values)
```

Parameters

value_dict (*dictionary*) – The output values in a dictionary of channel:value pairs.

Raises

- ***HatError*** – the board is not initialized, does not respond, or responds incorrectly.
- ***ValueError*** – an argument is invalid.

dio_output_read_bit(*channel*)

Read a single digital output channel value.

This function returns the value stored in the output register. It may not represent the value at the terminal if the channel is configured as input or open-drain output.

Parameters

channel (*int*) – The digital channel number, 0-7.

Returns

The output value.

Return type

int

Raises

- ***HatError*** – the board is not initialized, does not respond, or responds incorrectly.
- ***ValueError*** – an argument is invalid.

dio_output_read_port()

Read all digital output channel values.

Returns the values as an integer with a value of 0 - 255. Each channel is represented by a bit in the integer (bit 0 is channel 0, etc.) The value of a specific output can be found by examining the bit at that location.

This function returns the values stored in the output register. They may not represent the value at the terminal if the channel is configured as input or open-drain output.

Returns

int: The output values.

Raises

HatError – the board is not initialized, does not respond, or responds incorrectly.

dio_output_read_tuple()

Read all digital output channel values at once as a tuple.

Returns a tuple of all output values in channel order. For example, to compare the channel 1 output to the channel 3 output:

```
outputs = mcc152.dio_output_read_tuple()
if outputs[1] == outputs[3]:
    print("channel 1 and channel 3 outputs are the same")
```

This function returns the values stored in the output register. They may not represent the value at the terminal if the channel is configured as input or open-drain output.

Returns

tuple of int: The output values.

Raises

HatError – the board is not initialized, does not respond, or responds incorrectly.

dio_int_status_read_bit(channel)

Read the interrupt status for a single channel.

Returns 0 if the input is not generating an interrupt, 1 if it is generating an interrupt.

Returns

int: The interrupt status value.

Raises

- *HatError* – the board is not initialized, does not respond, or responds incorrectly.
- *ValueError* – an argument is invalid.

dio_int_status_read_port()

Read the interrupt status for all channels.

Returns the values as an integer with a value of 0 - 255. Each channel is represented by a bit in the integer (bit 0 is channel 0, etc.) The status for a specific input can be found by examining the bit at that location. Each bit will be 0 if the channel is not generating an interrupt or 1 if it is generating an interrupt.

Returns

int: The interrupt status values.

Raises

HatError – the board is not initialized, does not respond, or responds incorrectly.

dio_int_status_read_tuple()

Read the interrupt status for all channels as a tuple.

Returns a tuple of all interrupt status values in channel order. Each value will be 0 if the channel is not generating an interrupt or 1 if it is generating an interrupt. For example, to see if an interrupt has occurred on channel 2 or 4:

```
status = mcc152.dio_int_status_read_tuple()
if status[2] == 1 or status[4] == 1:
    print("an interrupt has occurred on channel 2 or 4")
```

Returns

tuple of int: The status values.

Raises

HatError – the board is not initialized, does not respond, or responds incorrectly.

dio_config_write_bit(channel, item, value)

Write a digital I/O configuration value for a single channel.

There are several configuration items that may be written for the digital I/O. The item is selected with the **item** argument, which may be one of the *DIOConfigItem* values:

- *DIOConfigItem.DIRECTION*: Set the digital I/O channel direction by passing 0 for output and 1 for input.
- *DIOConfigItem.PULL_CONFIG*: Configure the pull-up/down resistor by passing 0 for pull-down or 1 for pull-up. The resistor may be enabled or disabled with the *DIOConfigItem.PULL_ENABLE* item.
- *DIOConfigItem.PULL_ENABLE*: Enable or disable the pull-up/down resistor by passing 0 for disabled or 1 for enabled. The resistor is configured for pull-up/down with the *DIOConfigItem.PULL_CONFIG* item. The resistor is automatically disabled if the bit is set to output and is configured as open-drain.
- *DIOConfigItem.INPUT_INVERT*: Enable inverting the input by passing a 0 for normal input or 1 for inverted.
- *DIOConfigItem.INPUT_LATCH*: Enable input latching by passing 0 for non-latched or 1 for latched.

When the input is non-latched, reads show the current status of the input. A state change in the input generates an interrupt (if it is not masked). A read of the input clears the interrupt. If the input goes back to its initial logic state before the input is read, then the interrupt is cleared.

When the input is latched, a change of state of the input generates an interrupt and the input logic value is loaded into the input port register. A read of the input will clear the interrupt. If the input returns to its initial logic state before the input is read, then the interrupt is not cleared and the input register keeps the logic value that initiated the interrupt. The next read of the input will show the initial state. Care must be taken when using bit reads on the input when latching is enabled - the bit method still reads the entire input register so a change on another bit could be missed. It is best to use port or tuple input reads when using latching.

If the input is changed from latched to non-latched, a read from the input reflects the current terminal logic level. If the input is changed from non-latched to latched input, the read from the input represents the latched logic level.

- *DIOConfigItem.OUTPUT_TYPE*: Set the output type by writing 0 for push-pull or 1 for open-drain. This setting affects all outputs so is not a per-channel setting and the channel argument is ignored. It should be set to the desired type before using *DIOConfigItem.DIRECTION* item to set channels as outputs. Internal pull-up/down resistors are disabled when a bit is set to output and is configured as open-drain, so external resistors should be used.

- *DIOConfigItem.INT_MASK*: Enable or disable interrupt generation by masking the interrupt. Write 0 to enable the interrupt or 1 to mask (disable) it.

All MCC 152s share a single interrupt signal to the CPU, so when an interrupt occurs the user must determine the source, optionally act on the interrupt, then clear that source so that other interrupts may be detected. The current interrupt state may be read with *interrupt_state()*. A user program may wait for the interrupt to become active with *wait_for_interrupt()*, or may register an interrupt callback function with *interrupt_callback_enable()*. This allows the user to wait for a change on one or more inputs without constantly reading the inputs. The source of the interrupt may be determined by reading the interrupt status of each MCC 152 with *dio_int_status_read_bit()*, *dio_int_status_read_port()* or *dio_int_status_read_tuple()*, and all active interrupt sources must be cleared before the interrupt will become inactive. The interrupt is cleared by reading the input with *dio_input_read_bit()*, *dio_input_read_port()*, or *dio_input_read_tuple()*.

Parameters

- **channel** (*integer*) – The digital I/O channel, 0 - 7
- **item** (*integer*) – The configuration item, one of *DIOConfigItem*.
- **value** (*integer*) – The configuration value.

Raises

- **HatError** – the board is not initialized, does not respond, or responds incorrectly.
- **ValueError** – an argument is invalid.

`dio_config_write_port(item, value)`

Write a digital I/O configuration value for all channels.

There are several configuration items that may be written for the digital I/O. They are written for all channels at once using an 8-bit value passed in **value**, where each bit corresponds to a channel (bit 0 is channel 0, etc.) The item is selected with the **item** argument, which may be one of the *DIOConfigItem* values.

- *DIOConfigItem.DIRECTION*: Set the digital I/O channel directions by passing 0 in a bit for output and 1 for input.
- *DIOConfigItem.PULL_CONFIG*: Configure the pull-up/down resistors by passing 0 in a bit for pull-down or 1 for pull-up. The resistors may be enabled or disabled with the *DIOConfigItem.PULL_ENABLE* item.
- *DIOConfigItem.PULL_ENABLE*: Enable or disable pull-up/down resistors by passing 0 in a bit for disabled or 1 for enabled. The resistors are configured for pull-up/down with the *DIOConfigItem.PULL_CONFIG* item. The resistors are automatically disabled if the bits are set to output and configured as open-drain.
- *DIOConfigItem.INPUT_INVERT*: Enable inverting inputs by passing a 0 in a bit for normal input or 1 for inverted.
- *DIOConfigItem.INPUT_LATCH*: Enable input latching by passing 0 in a bit for non-latched or 1 for latched.

When the input is non-latched, reads show the current status of the input. A state change in the corresponding input generates an interrupt (if it is not masked). A read of the input clears the interrupt. If the input goes back to its initial logic state before the input is read, then the interrupt is cleared. When the input is latched, a change of state of the input generates an interrupt and the input logic value is loaded into the input port register. A read of the input will clear the interrupt. If the input returns to its initial logic state before the input is read, then the interrupt is not cleared and the input register keeps the logic value that initiated the interrupt. The next read of the input will show the initial state. Care

must be taken when using bit reads on the input when latching is enabled - the bit method still reads the entire input register so a change on another bit could be missed. It is best to use port or tuple input reads when using latching.

If the input is changed from latched to non-latched, a read from the input reflects the current terminal logic level. If the input is changed from non-latched to latched input, the read from the input represents the latched logic level.

- *DIOConfigItem.OUTPUT_TYPE*: Set the output type by writing 0 for push-pull or 1 for open-drain. This setting affects all outputs so is not a per-channel setting. It should be set to the desired type before using *DIOConfigItem.DIRECTION* to set channels as outputs. Internal pull-up/down resistors are disabled when a bit is set to output and is configured as open-drain, so external resistors should be used.
- *DIOConfigItem.INT_MASK*: Enable or disable interrupt generation for specific inputs by masking the interrupt. Write 0 in a bit to enable the interrupt from that channel or 1 to mask (disable) it.

All MCC 152s share a single interrupt signal to the CPU, so when an interrupt occurs the user must determine the source, optionally act on the interrupt, then clear that source so that other interrupts may be detected. The current interrupt state may be read with *interrupt_state()*. A user program may wait for the interrupt to become active with *wait_for_interrupt()*, or may register an interrupt callback function with *interrupt_callback_enable()*. This allows the user to wait for a change on one or more inputs without constantly reading the inputs. The source of the interrupt may be determined by reading the interrupt status of each MCC 152 with *dio_int_status_read_bit()*, *dio_int_status_read_port()* or *dio_int_status_read_tuple()*, and all active interrupt sources must be cleared before the interrupt will become inactive. The interrupt is cleared by reading the input with *dio_input_read_bit()*, *dio_input_read_port()*, or *dio_input_read_tuple()*.

Parameters

- **item** (*integer*) – The configuration item, one of *DIOConfigItem*.
- **value** (*integer*) – The configuration value.

Raises

- **HatError** – the board is not initialized, does not respond, or responds incorrectly.
- **ValueError** – an argument is invalid.

`dio_config_write_dict(item, value_dict)`

Write a digital I/O configuration value for multiple channels.

There are several configuration items that may be written for the digital I/O. They are written for multiple channels at once using a dictionary of channel:value pairs. If a channel is repeated in the dictionary then the last value will be used. The item is selected with the **item** argument, which may be one of the *DIOConfigItem* values:

- *DIOConfigItem.DIRECTION*: Set the digital I/O channel directions by passing 0 in a value for output and 1 for input.
- *DIOConfigItem.PULL_CONFIG*: Configure the pull-up/down resistors by passing 0 in a value for pull-down or 1 for pull-up. The resistors may be enabled or disabled with the *DIOConfigItem.PULL_ENABLE* item.
- *DIOConfigItem.PULL_ENABLE*: Enable or disable pull-up/down resistors by passing 0 in a value for disabled or 1 for enabled. The resistors are configured for pull-up/down with the *DIOConfigItem.PULL_CONFIG* item. The resistors are automatically disabled if the bits are set to output and configured as open-drain.

- *DIOConfigItem.INPUT_INVERT*: Enable inverting inputs by passing a 0 in a value for normal input or 1 for inverted.
- *DIOConfigItem.INPUT_LATCH*: Enable input latching by passing 0 in a value for non-latched or 1 for latched.

When the input is non-latched, reads show the current status of the input. A state change in the corresponding input generates an interrupt (if it is not masked). A read of the input clears the interrupt. If the input goes back to its initial logic state before the input is read, then the interrupt is cleared. When the input is latched, a change of state of the input generates an interrupt and the input logic value is loaded into the input port register. A read of the input will clear the interrupt. If the input returns to its initial logic state before the input is read, then the interrupt is not cleared and the input register keeps the logic value that initiated the interrupt. The next read of the input will show the initial state. Care must be taken when using bit reads on the input when latching is enabled - the bit method still reads the entire input register so a change on another bit could be missed. It is best to use port or tuple input reads when using latching.

If the input is changed from latched to non-latched, a read from the input reflects the current terminal logic level. If the input is changed from non-latched to latched input, the read from the input represents the latched logic level.

- *DIOConfigItem.OUTPUT_TYPE*: Set the output type by writing 0 for push-pull or 1 for open-drain. This setting affects all outputs so is not a per-channel setting. It should be set to the desired type before using *DIOConfigItem.DIRECTION* to set channels as outputs. Internal pull-up/down resistors are disabled when a bit is set to output and is configured as open-drain, so external resistors should be used.
- *DIOConfigItem.INT_MASK*: Enable or disable interrupt generation for specific inputs by masking the interrupt. Write 0 in a value to enable the interrupt from that channel or 1 to mask (disable) it.

All MCC 152s share a single interrupt signal to the CPU, so when an interrupt occurs the user must determine the source, optionally act on the interrupt, then clear that source so that other interrupts may be detected. The current interrupt state may be read with *interrupt_state()*. A user program may wait for the interrupt to become active with *wait_for_interrupt()*, or may register an interrupt callback function with *interrupt_callback_enable()*. This allows the user to wait for a change on one or more inputs without constantly reading the inputs. The source of the interrupt may be determined by reading the interrupt status of each MCC 152 with *dio_int_status_read_bit()*, *dio_int_status_read_port()* or *dio_int_status_read_tuple()*, and all active interrupt sources must be cleared before the interrupt will become inactive. The interrupt is cleared by reading the input with *dio_input_read_bit()*, *dio_input_read_port()*, or *dio_input_read_tuple()*.

For example, to set channels 6 and 7 to output:

```
values = { 6:0, 7:0 }
mcc152.dio_config_write_dict(DIOConfigItem.DIRECTION, values)
```

Parameters

- **item** (*integer*) – The configuration item, one of *DIOConfigItem*.
- **value_dict** (*dictionary*) – The configuration values for multiple channels in a dictionary of channel:value pairs.

Raises

- **HatError** – the board is not initialized, does not respond, or responds incorrectly.
- **ValueError** – an argument is invalid.

dio_config_read_bit(*channel*, *item*)

Read a digital I/O configuration value for a single channel.

There are several configuration items that may be read for the digital I/O. The item is selected with the **item** argument, which may be one of the `DIOConfigItem`s values:

- `DIOConfigItem.DIRECTION`: Read the digital I/O channel direction setting, where 0 is output and 1 is input.
- `DIOConfigItem.PULL_CONFIG`: Read the pull-up/down resistor configuration where 0 is pull-down and 1 is pull-up.
- `DIOConfigItem.PULL_ENABLE`: Read the pull-up/down resistor enable setting where 0 is disabled and 1 is enabled.
- `DIOConfigItem.INPUT_INVERT`: Read the input inversion setting where 0 is normal input and 1 is inverted.
- `DIOConfigItem.INPUT_LATCH`: Read the input latching setting where 0 is non-latched and 1 is latched.
- `DIOConfigItem.OUTPUT_TYPE`: Read the output type setting where 0 is push-pull and 1 is open-drain. This setting affects all outputs so is not a per-channel setting and the channel argument is ignored.
- `DIOConfigItem.INT_MASK`: Read the interrupt mask setting where 0 in a bit enables the interrupt and 1 disables it.

Parameters

- **channel** (*integer*) – The digital I/O channel, 0 - 7.
- **item** (*integer*) – The configuration item, one of `DIOConfigItem`.

Returns

int: The configuration item value.

Raises

- **HatError** – the board is not initialized, does not respond, or responds incorrectly.
- **ValueError** – an argument is invalid.

dio_config_read_port(*item*)

Read a digital I/O configuration value for all channels.

There are several configuration items that may be read for the digital I/O. They are read for all channels at once, returning an 8-bit integer where each bit corresponds to a channel (bit 0 is channel 0, etc.) The item is selected with the **item** argument, which may be one of the `DIOConfigItem` values:

- `DIOConfigItem.DIRECTION`: Read the digital I/O channels direction settings, where 0 in a bit is output and 1 is input.
- `DIOConfigItem.PULL_CONFIG`: Read the pull-up/down resistor configurations where 0 in a bit is pull-down and 1 is pull-up.
- `DIOConfigItem.PULL_ENABLE`: Read the pull-up/down resistor enable settings where 0 in a bit is disabled and 1 is enabled.
- `DIOConfigItem.INPUT_INVERT`: Read the input inversion settings where 0 in a bit is normal input and 1 is inverted.

- *DIOConfigItem.INPUT_LATCH*: Read the input latching settings where 0 in a bit is non-latched and 1 is latched.
- *DIOConfigItem.OUTPUT_TYPE*: Read the output type setting where 0 is push-pull and 1 is open-drain. This setting affects all outputs so is not a per-channel setting.
- *DIOConfigItem.INT_MASK*: Read the interrupt mask settings where 0 in a bit enables the interrupt and 1 disables it.

Parameters

item (*integer*) – The configuration item, one of *DIOConfigItem*.

Returns

int: The configuration item value.

Raises

- **HatError** – the board is not initialized, does not respond, or responds incorrectly.
- **ValueError** – an argument is invalid.

dio_config_read_tuple(*item*)

Read a digital I/O configuration value for all channels as a tuple.

There are several configuration items that may be read for the digital I/O. They are read for all channels at once, returning a tuple in channel order. The item is selected with the **item** argument, which may be one of the *DIOConfigItem* values:

- *DIOConfigItem.DIRECTION*: Read the digital I/O channels direction settings, where 0 in a value is output and 1 is input.
- *DIOConfigItem.PULL_CONFIG*: Read the pull-up/down resistor configurations where 0 in a value is pull-down and 1 is pull-up.
- *DIOConfigItem.PULL_ENABLE*: Read the pull-up/down resistor enable settings where 0 in a value is disabled and 1 is enabled.
- *DIOConfigItem.INPUT_INVERT*: Read the input inversion settings where 0 in a value is normal input and 1 is inverted.
- *DIOConfigItem.INPUT_LATCH*: Read the input latching settings where 0 in a value is non-latched and 1 is latched.
- *DIOConfigItem.OUTPUT_TYPE*: Read the output type setting where 0 is push-pull and 1 is open-drain. This setting affects all outputs so is not a per-channel setting.
- *DIOConfigItem.INT_MASK*: Read the interrupt mask settings where 0 in a value enables the interrupt and 1 disables it.

Parameters

item (*integer*) – The configuration item, one of *DIOConfigItem*.

Returns

tuple of int: The configuration item values.

Raises

- **HatError** – the board is not initialized, does not respond, or responds incorrectly.
- **ValueError** – an argument is invalid.

address()

Return the device address.

5.5.2 Data

5.5.2.1 DIO Config Items

```
class daqhats.DIOConfigItem(value, names=None, *, module=None, qualname=None, type=None, start=1,
                             boundary=None)
```

Digital I/O Configuration Items.

DIRECTION = 0

Configure channel direction

PULL_CONFIG = 1

Configure pull-up/down resistor

PULL_ENABLE = 2

Enable pull-up/down resistor

INPUT_INVERT = 3

Configure input inversion

INPUT_LATCH = 4

Configure input latching

OUTPUT_TYPE = 5

Configure output type

INT_MASK = 6

Configure interrupt mask

5.6 MCC 172 class

5.6.1 Methods

```
class daqhats.mcc172(address=0)
```

The class for an MCC 172 board.

Parameters

address (*int*) – board address, must be 0-7.

Raises

HatError – the board did not respond or was of an incorrect type

Methods

Method	Description
<code>mcc172.info()</code>	Get info about this device type.
<code>mcc172.firmware_version()</code>	Get the firmware version.
<code>mcc172.serial()</code>	Read the serial number.
<code>mcc172.blink_led()</code>	Blink the MCC 172 LED.
<code>mcc172.calibration_date()</code>	Read the calibration date.
<code>mcc172.calibration_coefficient_read()</code>	Read the calibration coefficients for a channel.
<code>mcc172.calibration_coefficient_write()</code>	Write the calibration coefficients for a channel.
<code>mcc172.iepe_config_read()</code>	Read the IEPE configuration for a channel.
<code>mcc172.iepe_config_write()</code>	Write the IEPE configuration for a channel.
<code>mcc172.a_in_sensitivity_read()</code>	Read the sensitivity factor for a channel.
<code>mcc172.a_in_sensitivity_write()</code>	Write the sensitivity factor for a channel.
<code>mcc172.a_in_clock_config_read()</code>	Read the sampling clock configuration.
<code>mcc172.a_in_clock_config_write()</code>	Write the sampling clock configuration.
<code>mcc172.trigger_config()</code>	Configure the external trigger input.
<code>mcc172.a_in_scan_actual_rate()</code>	Read the actual sample rate for a requested sample rate.
<code>mcc172.a_in_scan_start()</code>	Start a hardware-paced analog input scan.
<code>mcc172.a_in_scan_buffer_size()</code>	Read the size of the internal scan data buffer.
<code>mcc172.a_in_scan_read()</code>	Read scan status / data (list).
<code>mcc172.a_in_scan_read_numpy()</code>	Read scan status / data (NumPy array).
<code>mcc172.a_in_scan_channel_count()</code>	Get the number of channels in the current scan.
<code>mcc172.a_in_scan_stop()</code>	Stop the scan.
<code>mcc172.a_in_scan_cleanup()</code>	Free scan resources.
<code>mcc172.address()</code>	Read the board's address.

static info()

Return constant information about this type of device.

Returns

A namedtuple containing the following field names:

- **NUM_AI_CHANNELS** (int): The number of analog input channels (2.)
- **AI_MIN_CODE** (int): The minimum ADC code (-8388608.)
- **AI_MAX_CODE** (int): The maximum ADC code (8388607.)
- **AI_MIN_VOLTAGE** (float): The voltage corresponding to the minimum ADC code (-5.0.)
- **AI_MAX_VOLTAGE** (float): The voltage corresponding to the maximum ADC code (+5.0 - 1 LSB)
- **AI_MIN_RANGE** (float): The minimum voltage of the input range (-5.0.)
- **AI_MAX_RANGE** (float): The maximum voltage of the input range (+5.0.)

Return type

namedtuple

firmware_version()

Read the board firmware and bootloader versions.

Returns

A namedtuple containing the following field names:

- **version** (string): The firmware version, i.e “1.03”.

Return type

namedtuple

Raises

HatError – the board is not initialized, does not respond, or responds incorrectly.

serial()

Read the serial number.

Returns

The serial number.

Return type

string

Raises

HatError – the board is not initialized, does not respond, or responds incorrectly.

blink_led(count)

Blink the MCC 172 LED.

Setting count to 0 will cause the LED to blink continuously until blink_led() is called again with a non-zero count.

Parameters

count (*int*) – The number of times to blink (max 255).

Raises

HatError – the board is not initialized, does not respond, or responds incorrectly.

calibration_date()

Read the calibration date.

Returns

The calibration date in the format “YYYY-MM-DD”.

Return type

string

Raises

HatError – the board is not initialized, does not respond, or responds incorrectly.

calibration_coefficient_read(channel)

Read the calibration coefficients for a single channel.

The coefficients are applied in the library as:

```
calibrated_ADC_code = (raw_ADC_code - offset) * slope
```

Parameters

channel (*int*) – The analog input channel (0-1.)

Returns

A namedtuple containing the following field names:

- **slope** (float): The slope.

- **offset** (*float*): The offset.

Return type

namedtuple

Raises*HatError* – the board is not initialized, does not respond, or responds incorrectly.**calibration_coefficient_write**(*channel*, *slope*, *offset*)

Temporarily write the calibration coefficients for a single channel.

The user can apply their own calibration coefficients by writing to these values. The values will reset to the factory values from the EEPROM whenever the class is initialized. This function will fail and raise a *HatError* exception if a scan is active when it is called.

The coefficients are applied in the library as:

```
calibrated_ADC_code = (raw_ADC_code - offset) * slope
```

Parameters

- **channel** (*int*) – The analog input channel (0-1.)
- **slope** (*float*) – The new slope value.
- **offset** (*float*) – The new offset value.

Raises*HatError* – the board is not initialized, does not respond, or responds incorrectly.**iepe_config_write**(*channel*, *mode*)

Configure a channel for an IEPE sensor.

This method turns on / off the IEPE power supply for the specified channel. The power-on default is IEPE power off.

Parameters

- **channel** (*int*) – The channel, 0 or 1.
- **mode** (*int*) – The IEPE mode for the channel, 0 = IEPE off, 1 = IEPE on.

Raises*HatError* – the board is not initialized, does not respond, or responds incorrectly.**iepe_config_read**(*channel*)

Read the IEPE configuration for a channel.

This method returns the state of the IEPE power supply for the specified channel

Parameters

- channel** (*int*) – The channel, 0 or 1.

Returns

int: The IEPE mode for the channel, 0 = IEPE off, 1 = IEPE on.

Raises*HatError* – the board is not initialized, does not respond, or responds incorrectly.

`a_in_sensitivity_write(channel, value)`

Write the MCC 172 analog input sensitivity scaling factor for a single channel.

This applies a scaling factor to the analog input data so it returns values that are meaningful for the connected sensor.

The sensitivity is specified in mV / mechanical unit. The default value when opening the library is 1000, resulting in no scaling of the input voltage. Changing this value will not change the values reported by `info()` since it is simply sensor scaling applied to the data before returning it.

Examples:

- A seismic sensor with a sensitivity of 10 V/g. Set the sensitivity to 10,000 and the returned data will be in units of g.
- A vibration sensor with a sensitivity of 100 mV/g. Set the sensitivity to 100 and the returned data will be in units of g.

Parameters

- **channel** (*int*) – The channel, 0 or 1.
- **value** (*float*) – The sensitivity for the specified channel.

Raises

HatError – the board is not initialized, does not respond, or responds incorrectly.

`a_in_sensitivity_read(channel)`

Read the MCC 172 analog input sensitivity scaling factor for a single channel.

The sensitivity is returned in mV / mechanical unit. The default value when opening the library is 1000, resulting in no scaling of the input voltage.

Parameters

- **channel** (*int*) – The channel, 0 or 1.

Returns

float: The sensitivity factor for the channel.

Raises

HatError – the board is not initialized, does not respond, or responds incorrectly.

`a_in_clock_config_write(clock_source, sample_rate_per_channel)`

Configure the ADC sampling clock.

This method will configure the ADC sampling clock. The default configuration after opening the device is local mode, 51.2 KHz sampling rate. The clock source must be one of:

- **SourceType.LOCAL**: the clock is generated on this MCC 172 and not shared with any other devices.
- **SourceType.MASTER**: the clock is generated on this MCC 172 and shared over the Raspberry Pi header with other MCC 172s. All other MCC 172s must be configured for local or slave clock.
- **SourceType.SLAVE**: no clock is generated on this MCC 172, it receives its clock from the Raspberry Pi header. Another MCC 172 must be configured for master clock.

The ADCs will be synchronized so they sample the inputs at the same time. This requires 128 clock cycles before the first sample is available. When using a master - slave clock configuration there are additional considerations:

- There should be only one master device; otherwise, you will be connecting multiple outputs together and could damage a device.
- Configure the clock on the slave device(s) first, master last. The synchronization will occur when the master clock is configured, causing the ADCs on all the devices to be in sync.
- If you change the clock configuration on one device after configuring the master, then the data will no longer be in sync. The devices cannot detect this and will still report that they are synchronized. Always write the clock configuration to all devices when modifying the configuration.
- Slave devices must have a master clock source or scans will never complete.
- A trigger must be used for the data streams from all devices to start on the same sample.

The MCC 172 can generate a sampling clock equal to 51.2 KHz divided by an integer between 1 and 256. The `sample_rate_per_channel` will be internally converted to the nearest valid rate. The actual rate can be read back using `a_in_clock_config_read()`. When used in slave clock configuration, the device will measure the frequency of the incoming master clock after the synchronization period is complete. Calling `a_in_clock_config_read()` after this will return the measured sample rate.

Parameters

- `clock_source` (*SourceType*) – The ADC clock source.
- `sample_rate_per_channel` (*float*) – The requested sampling rate in samples per second per channel.

Raises

HatError – the board is not initialized, does not respond, or responds incorrectly.

`a_in_clock_config_read()`

Read the sampling clock configuration.

This method will return the sample clock configuration and rate. If the clock is configured for local or master source, then the rate will be the internally adjusted rate set by the user. If the clock is configured for slave source, then the rate will be measured from the master clock after the synchronization period has ended. The synchronization status is also returned.

The clock source will be one of:

- *SourceType.LOCAL*: the clock is generated on this MCC 172 and not shared with any other devices.
- *SourceType.MASTER*: the clock is generated on this MCC 172 and shared over the Raspberry Pi header with other MCC 172s.
- *SourceType.SLAVE*: no clock is generated on this MCC 172, it receives its clock from the Raspberry Pi header.

The sampling rate will not be valid in slave mode if `synced` is `False`. The device will not detect a loss of the master clock when in slave mode; it only monitors the clock when a sync is initiated.

Returns

namedtuple: a namedtuple containing the following field names:

- `clock_source` (*SourceType*): The ADC clock source.
- `sample_rate_per_channel` (*float*): The sample rate in samples per second per channel.
- `synchronized` (*bool*): True if the ADCs are synchronized, False if a synchronization is in progress.

Raises

HatError – the board is not initialized, does not respond, or responds incorrectly.

trigger_config(*trigger_source*, *trigger_mode*)

Configure the digital trigger.

The analog input scan may be configured to start saving the acquired data when the digital trigger is in the desired state. A single device trigger may also be shared with multiple boards. This command sets the trigger source and mode.

The trigger source must be one of:

- *SourceType.LOCAL*: the trigger terminal on this MCC 172 is used and not shared with any other devices.
- *SourceType.MASTER*: the trigger terminal on this MCC 172 is used and is shared as the master trigger for other MCC 172s.
- *SourceType.SLAVE*: the trigger terminal on this MCC 172 is not used, it receives its trigger from the master MCC 172.

The trigger mode must be one of:

- *TriggerModes.RISING_EDGE*: Start saving data when the trigger transitions from low to high.
- *TriggerModes.FALLING_EDGE*: Start saving data when the trigger transitions from high to low.
- *TriggerModes.ACTIVE_HIGH*: Start saving data when the trigger is high.
- *TriggerModes.ACTIVE_LOW*: Start saving data when the trigger is low.

Due to the nature of the filtering in the A/D converters there is an input delay of 39 samples, so the data coming from the converters at any time is delayed by 39 samples from the current time. This is most noticeable when using a trigger - there will be approximately 39 samples prior to the trigger event in the captured data.

Care must be taken when using master / slave triggering; the input trigger signal on the master will be passed through to the slave(s), but the mode is set independently on each device. For example, it is possible for the master to trigger on the rising edge of the signal and the slave to trigger on the falling edge.

Parameters

- **trigger_source** (*SourceType*) – The trigger source.
- **trigger_mode** (*TriggerModes*) – The trigger mode.

Raises

HatError – the board is not initialized, does not respond, or responds incorrectly.

static a_in_scan_actual_rate(*sample_rate_per_channel*)

Calculate the actual sample rate per channel for a requested sample rate.

The scan clock is generated from a 51.2 KHz clock source divided by an integer between 1 and 256, so only discrete frequency steps can be achieved. This method will return the actual rate for a requested sample rate.

This function does not perform any actions with a board, it simply calculates the rate.

Parameters

sample_rate_per_channel (*float*) – The desired per-channel rate of the internal sampling clock.

Returns

The actual sample rate.

Return type

float

a_in_scan_start(*channel_mask*, *samples_per_channel*, *options*)

Start capturing analog input data.

The scan runs as a separate thread from the user's code. This function will allocate a scan buffer and start the thread that reads data from the device into that buffer. The user reads the data from the scan buffer and the scan status using the `a_in_scan_read()` function. `a_in_scan_stop()` is used to stop a continuous scan, or to stop a finite scan before it completes. The user must call `a_in_scan_cleanup()` after the scan has finished and all desired data has been read; this frees all resources from the scan and allows additional scans to be performed.

The scan cannot be started until the ADCs are synchronized, so this function will not return until that has completed. It is best to wait for sync using `a_in_clock_config_read()` before starting the scan.

The scan state has defined terminology:

- **Active:** `a_in_scan_start()` has been called and the device may be acquiring data or finished with the acquisition. The scan has not been cleaned up by calling `a_in_scan_cleanup()`, so another scan may not be started.
- **Running:** The scan is active and the device is still acquiring data. Certain methods like `a_in_clock_config_write()` will return an error because the device is busy.

The scan options that may be used are:

- `OptionFlags.DEFAULT`: Return scaled and calibrated data, do not use a trigger, and finite operation. Any other flags will override DEFAULT behavior.
- `OptionFlags.NOSCALEDATA`: Return ADC codes (values between -8,388,608 and 8,388,607) rather than voltage.
- `OptionFlags.NOALIBRATEDATA`: Return data without the calibration factors applied.
- `OptionFlags.EXTTRIGGER`: Do not start saving data (after calling `a_in_scan_start()`) until the trigger condition is met. The trigger is configured with `trigger_config()`.
- `OptionFlags.CONTINUOUS`: Read analog data continuously until stopped by the user by calling `a_in_scan_stop()` and write data to a circular buffer. The data must be read before being overwritten to avoid a buffer overrun error. **samples_per_channel** is only used for buffer sizing.

The `OptionFlags.EXTCLOCK` option is not supported for this device and will raise a `ValueError`.

The scan buffer size will be allocated as follows:

Finite mode: Total number of samples in the scan.

Continuous mode: Either **samples_per_channel** or the value in the table below, whichever is greater.

Sample Rate	Buffer Size (per channel)
200-1024 S/s	1 kS
1280-10.24 kS/s	10 kS
12.8 kS or higher	100 kS

Specifying a very large value for `samples_per_channel` could use too much of the Raspberry Pi memory. If the memory allocation fails, the function will raise a `HatError` with this description. The allocation could succeed, but the lack of free memory could cause other problems in the Raspberry Pi. If you need to acquire a high number of samples then it is better to run the scan in continuous mode and stop it when you have acquired the desired amount of data. If a scan is active this method will raise a `HatError`.

Parameters

- **channel_mask** (*int*) – A bit mask of the desired channels (0x01 - 0x03).

- **samples_per_channel** (*int*) – The number of samples to acquire per channel (finite mode,) or or can be used to set a larger scan buffer size than the default value (continuous mode.)
- **options** (*int*) – An ORed combination of *OptionFlags* flags that control the scan.

Raises

- **HatError** – a scan is active; memory could not be allocated; the board is not initialized, does not respond, or responds incorrectly.
- **ValueError** – a scan argument is invalid.

a_in_scan_buffer_size()

Read the internal scan data buffer size.

An internal data buffer is allocated for the scan when *a_in_scan_start()* is called. This function returns the total size of that buffer in samples.

Returns

The buffer size in samples.

Return type

int

Raises

HatError – the board is not initialized or no scan buffer is allocated (a scan is not active).

a_in_scan_status()

Read scan status and number of available samples per channel.

The analog input scan is started with *a_in_scan_start()* and runs in the background. This function reads the status of that background scan and the number of samples per channel available in the scan thread buffer.

Returns

A namedtuple containing the following field names:

- **running** (bool): True if the scan is running, False if it has stopped or completed.
- **hardware_overrun** (bool): True if the hardware could not acquire and unload samples fast enough and data was lost.
- **buffer_overrun** (bool): True if the background scan buffer was not read fast enough and data was lost.
- **triggered** (bool): True if the trigger conditions have been met and data acquisition started.
- **samples_available** (int): The number of samples per channel currently in the scan buffer.

Return type

namedtuple

Raises

HatError – A scan is not active, the board is not initialized, does not respond, or responds incorrectly.

a_in_scan_read(samples_per_channel, timeout)

Read scan status and data (as a list).

The analog input scan is started with *a_in_scan_start()* and runs in the background. This function reads the status of that background scan and optionally reads sampled data from the scan buffer.

Parameters

- **samples_per_channel** (*int*) – The number of samples per channel to read from the scan buffer. Specify a negative number to return all available samples immediately and ignore **timeout** or 0 to only read the scan status and return no data.
- **timeout** (*float*) – The amount of time in seconds to wait for the samples to be read. Specify a negative number to wait indefinitely, or 0 to return immediately with the samples that are already in the scan buffer (up to **samples_per_channel**.) If the timeout is met and the specified number of samples have not been read, then the function will return all the available samples and the timeout status set.

Returns

A namedtuple containing the following field names:

- **running** (bool): True if the scan is running, False if it has stopped or completed.
- **hardware_overrun** (bool): True if the hardware could not acquire and unload samples fast enough and data was lost.
- **buffer_overrun** (bool): True if the background scan buffer was not read fast enough and data was lost.
- **triggered** (bool): True if the trigger conditions have been met and data acquisition started.
- **timeout** (bool): True if the timeout time expired before the specified number of samples were read.
- **data** (list of float): The data that was read from the scan buffer.

Return type

namedtuple

Raises

- **HatError** – A scan is not active, the board is not initialized, does not respond, or responds incorrectly.
- **ValueError** – Incorrect argument.

a_in_scan_read_numpy(*samples_per_channel*, *timeout*)

Read scan status and data (as a NumPy array).

This function is similar to `a_in_scan_read()` except that the *data* key in the returned namedtuple is a NumPy array of float64 values and may be used directly with NumPy functions.

Parameters

- **samples_per_channel** (*int*) – The number of samples per channel to read from the scan buffer. Specify a negative number to read all available samples or 0 to only read the scan status and return no data.
- **timeout** (*float*) – The amount of time in seconds to wait for the samples to be read. Specify a negative number to wait indefinitely, or 0 to return immediately with the samples that are already in the scan buffer. If the timeout is met and the specified number of samples have not been read, then the function will return with the amount that has been read and the timeout status set.

Returns

A namedtuple containing the following field names:

- **running** (bool): True if the scan is running, False if it has stopped or completed.
- **hardware_overrun** (bool): True if the hardware could not acquire and unload samples fast enough and data was lost.

- **buffer_overflow** (bool): True if the background scan buffer was not read fast enough and data was lost.
- **triggered** (bool): True if the trigger conditions have been met and data acquisition started.
- **timeout** (bool): True if the timeout time expired before the specified number of samples were read.
- **data** (NumPy array of float64): The data that was read from the scan buffer.

Return type

namedtuple

Raises

- **HatError** – A scan is not active, the board is not initialized, does not respond, or responds incorrectly.
- **ValueError** – Incorrect argument.

a_in_scan_channel_count()

Read the number of channels in the current analog input scan.

Returns

The number of channels (0 if no scan is active, 1-2 otherwise.)

Return type

int

Raises

HatError – the board is not initialized, does not respond, or responds incorrectly.

a_in_scan_stop()

Stops an analog input scan.

The device stops acquiring data immediately. The scan data that has been read into the scan buffer is available until [a_in_scan_cleanup\(\)](#) is called.

Raises

HatError – the board is not initialized, does not respond, or responds incorrectly.

a_in_scan_cleanup()

Free analog input scan resources after the scan is complete.

This will free the scan buffer and other resources used by the background scan and make it possible to start another scan with [a_in_scan_start\(\)](#).

Raises

HatError – the board is not initialized, does not respond, or responds incorrectly.

address()

Return the device address.

5.6.2 Data

5.6.2.1 Source types

class `daqhats.SourceType`(*value, names=None, *, module=None, qualname=None, type=None, start=1, boundary=None*)

Clock / trigger source options.

LOCAL = 0

Use a local-only source.

MASTER = 1

Use a local source and set it as master.

SLAVE = 2

Use a master source from another MCC 172.

A

- `a_in_clock_config_read()` (*daqhats.mcc172 method*), 145
- `a_in_clock_config_write()` (*daqhats.mcc172 method*), 144
- `a_in_mode_read()` (*daqhats.mcc128 method*), 116
- `a_in_mode_write()` (*daqhats.mcc128 method*), 115
- `a_in_range_read()` (*daqhats.mcc128 method*), 116
- `a_in_range_write()` (*daqhats.mcc128 method*), 116
- `a_in_read()` (*daqhats.mcc118 method*), 107
- `a_in_read()` (*daqhats.mcc128 method*), 116
- `a_in_read()` (*daqhats.mcc134 method*), 125
- `a_in_scan_actual_rate()` (*daqhats.mcc118 method*), 108
- `a_in_scan_actual_rate()` (*daqhats.mcc128 method*), 117
- `a_in_scan_actual_rate()` (*daqhats.mcc172 static method*), 146
- `a_in_scan_buffer_size()` (*daqhats.mcc118 method*), 110
- `a_in_scan_buffer_size()` (*daqhats.mcc128 method*), 118
- `a_in_scan_buffer_size()` (*daqhats.mcc172 method*), 148
- `a_in_scan_channel_count()` (*daqhats.mcc118 method*), 112
- `a_in_scan_channel_count()` (*daqhats.mcc128 method*), 121
- `a_in_scan_channel_count()` (*daqhats.mcc172 method*), 150
- `a_in_scan_cleanup()` (*daqhats.mcc118 method*), 112
- `a_in_scan_cleanup()` (*daqhats.mcc128 method*), 121
- `a_in_scan_cleanup()` (*daqhats.mcc172 method*), 150
- `a_in_scan_read()` (*daqhats.mcc118 method*), 110
- `a_in_scan_read()` (*daqhats.mcc128 method*), 119
- `a_in_scan_read()` (*daqhats.mcc172 method*), 148
- `a_in_scan_read_numpy()` (*daqhats.mcc118 method*), 111
- `a_in_scan_read_numpy()` (*daqhats.mcc128 method*), 120
- `a_in_scan_read_numpy()` (*daqhats.mcc172 method*), 149
- `a_in_scan_start()` (*daqhats.mcc118 method*), 108
- `a_in_scan_start()` (*daqhats.mcc128 method*), 117
- `a_in_scan_start()` (*daqhats.mcc172 method*), 146
- `a_in_scan_status()` (*daqhats.mcc118 method*), 110
- `a_in_scan_status()` (*daqhats.mcc128 method*), 119
- `a_in_scan_status()` (*daqhats.mcc172 method*), 148
- `a_in_scan_stop()` (*daqhats.mcc118 method*), 112
- `a_in_scan_stop()` (*daqhats.mcc128 method*), 121
- `a_in_scan_stop()` (*daqhats.mcc172 method*), 150
- `a_in_sensitivity_read()` (*daqhats.mcc172 method*), 144
- `a_in_sensitivity_write()` (*daqhats.mcc172 method*), 143
- `a_out_write()` (*daqhats.mcc152 method*), 129
- `a_out_write_all()` (*daqhats.mcc152 method*), 129
- ACTIVE_HIGH (*daqhats.TriggerModes attribute*), 104
- ACTIVE_LOW (*daqhats.TriggerModes attribute*), 104
- `address()` (*daqhats.mcc118 method*), 112
- `address()` (*daqhats.mcc128 method*), 121
- `address()` (*daqhats.mcc134 method*), 126
- `address()` (*daqhats.mcc152 method*), 139
- `address()` (*daqhats.mcc172 method*), 150
- AnalogInputMode (*C enum*), 74
- AnalogInputMode (*class in daqhats*), 121
- AnalogInputMode.A_IN_MODE_DIFF (*C enumerator*), 74
- AnalogInputMode.A_IN_MODE_SE (*C enumerator*), 74
- AnalogInputRange (*C enum*), 74
- AnalogInputRange (*class in daqhats*), 121
- AnalogInputRange.A_IN_RANGE_BIP_10V (*C enumerator*), 74
- AnalogInputRange.A_IN_RANGE_BIP_1V (*C enumerator*), 74
- AnalogInputRange.A_IN_RANGE_BIP_2V (*C enumerator*), 74
- AnalogInputRange.A_IN_RANGE_BIP_5V (*C enumerator*), 74
- ANY (*daqhats.HatIDs attribute*), 103

B

- BIP_10V (*daqhats.AnalogInputRange attribute*), 121
- BIP_1V (*daqhats.AnalogInputRange attribute*), 122

BIP_2V (*daqhats.AnalogInputRange attribute*), 122

BIP_5V (*daqhats.AnalogInputRange attribute*), 121

blink_led() (*daqhats.mcc118 method*), 106

blink_led() (*daqhats.mcc128 method*), 114

blink_led() (*daqhats.mcc172 method*), 142

C

calibration_coefficient_read() (*daqhats.mcc118 method*), 106

calibration_coefficient_read() (*daqhats.mcc128 method*), 114

calibration_coefficient_read() (*daqhats.mcc134 method*), 123

calibration_coefficient_read() (*daqhats.mcc172 method*), 142

calibration_coefficient_write() (*daqhats.mcc118 method*), 107

calibration_coefficient_write() (*daqhats.mcc128 method*), 115

calibration_coefficient_write() (*daqhats.mcc134 method*), 124

calibration_coefficient_write() (*daqhats.mcc172 method*), 143

calibration_date() (*daqhats.mcc118 method*), 106

calibration_date() (*daqhats.mcc128 method*), 114

calibration_date() (*daqhats.mcc134 method*), 123

calibration_date() (*daqhats.mcc172 method*), 142

cjc_read() (*daqhats.mcc134 method*), 126

COMMON_MODE_TC_VALUE (*C macro*), 79

COMMON_MODE_TC_VALUE (*daqhats.mcc134 attribute*), 122

CONTINUOUS (*daqhats.OptionFlags attribute*), 104

D

DEFAULT (*daqhats.OptionFlags attribute*), 104

DIFF (*daqhats.AnalogInputMode attribute*), 121

dio_config_read_bit() (*daqhats.mcc152 method*), 137

dio_config_read_port() (*daqhats.mcc152 method*), 138

dio_config_read_tuple() (*daqhats.mcc152 method*), 139

dio_config_write_bit() (*daqhats.mcc152 method*), 134

dio_config_write_dict() (*daqhats.mcc152 method*), 136

dio_config_write_port() (*daqhats.mcc152 method*), 135

dio_input_read_bit() (*daqhats.mcc152 method*), 130

dio_input_read_port() (*daqhats.mcc152 method*), 130

dio_input_read_tuple() (*daqhats.mcc152 method*), 131

dio_int_status_read_bit() (*daqhats.mcc152 method*), 133

dio_int_status_read_port() (*daqhats.mcc152 method*), 133

dio_int_status_read_tuple() (*daqhats.mcc152 method*), 133

dio_output_read_bit() (*daqhats.mcc152 method*), 132

dio_output_read_port() (*daqhats.mcc152 method*), 132

dio_output_read_tuple() (*daqhats.mcc152 method*), 133

dio_output_write_bit() (*daqhats.mcc152 method*), 131

dio_output_write_dict() (*daqhats.mcc152 method*), 132

dio_output_write_port() (*daqhats.mcc152 method*), 131

dio_reset() (*daqhats.mcc152 method*), 129

DIOConfigItem (*C enum*), 89

DIOConfigItem (*class in daqhats*), 140

DIOConfigItem.DIO_DIRECTION (*C enumerator*), 89

DIOConfigItem.DIO_INPUT_INVERT (*C enumerator*), 90

DIOConfigItem.DIO_INPUT_LATCH (*C enumerator*), 90

DIOConfigItem.DIO_INT_MASK (*C enumerator*), 90

DIOConfigItem.DIO_OUTPUT_TYPE (*C enumerator*), 90

DIOConfigItem.DIO_PULL_CONFIG (*C enumerator*), 89

DIOConfigItem.DIO_PULL_ENABLE (*C enumerator*), 90

DIRECTION (*daqhats.DIOConfigItem attribute*), 140

DISABLED (*daqhats.TcTypes attribute*), 127

E

EXTCLOCK (*daqhats.OptionFlags attribute*), 104

EXTTRIGGER (*daqhats.OptionFlags attribute*), 104

F

FALLING_EDGE (*daqhats.TriggerModes attribute*), 104

firmware_version() (*daqhats.mcc118 method*), 106

firmware_version() (*daqhats.mcc128 method*), 114

firmware_version() (*daqhats.mcc172 method*), 141

H

hat_error_message (*C function*), 52

hat_interrupt_callback_disable (*C function*), 53

hat_interrupt_callback_enable (*C function*), 52

hat_interrupt_state (*C function*), 52

hat_list (*C function*), 51

hat_list() (*in module daqhats*), 101

hat_wait_for_interrupt (*C function*), 52

- HatError, 104
 HatIDs (C enum), 53
 HatIDs (class in daqhats), 103
 HatIDs.HAT_ID_ANY (C enumerator), 53
 HatIDs.HAT_ID_MCC_118 (C enumerator), 53
 HatIDs.HAT_ID_MCC_118_BOOTLOADER (C enumerator), 53
 HatIDs.HAT_ID_MCC_128 (C enumerator), 54
 HatIDs.HAT_ID_MCC_134 (C enumerator), 54
 HatIDs.HAT_ID_MCC_152 (C enumerator), 54
 HatIDs.HAT_ID_MCC_172 (C enumerator), 54
 HatInfo (C struct), 55
 HatInfo.address (C var), 55
 HatInfo.id (C var), 55
 HatInfo.product_name (C var), 55
 HatInfo.version (C var), 55
- I**
- iepe_config_read() (daqhats.mcc172 method), 143
 iepe_config_write() (daqhats.mcc172 method), 143
 info() (daqhats.mcc118 static method), 105
 info() (daqhats.mcc128 static method), 113
 info() (daqhats.mcc134 static method), 122
 info() (daqhats.mcc152 static method), 128
 info() (daqhats.mcc172 static method), 141
 INPUT_INVERT (daqhats.DIOConfigItem attribute), 140
 INPUT_LATCH (daqhats.DIOConfigItem attribute), 140
 INT_MASK (daqhats.DIOConfigItem attribute), 140
 interrupt_callback_disable() (in module daqhats), 103
 interrupt_callback_enable() (in module daqhats), 102
 interrupt_state() (in module daqhats), 101
- L**
- LOCAL (daqhats.SourceType attribute), 151
- M**
- MASTER (daqhats.SourceType attribute), 151
 MAX_NUMBER_HATS (C macro), 53
 mcc118 (class in daqhats), 105
 mcc118_a_in_read (C function), 59
 mcc118_a_in_scan_actual_rate (C function), 60
 mcc118_a_in_scan_buffer_size (C function), 62
 mcc118_a_in_scan_channel_count (C function), 63
 mcc118_a_in_scan_cleanup (C function), 63
 mcc118_a_in_scan_read (C function), 62
 mcc118_a_in_scan_start (C function), 60
 mcc118_a_in_scan_status (C function), 62
 mcc118_a_in_scan_stop (C function), 63
 mcc118_blink_led (C function), 58
 mcc118_calibration_coefficient_read (C function), 58
 mcc118_calibration_coefficient_write (C function), 59
 mcc118_calibration_date (C function), 58
 mcc118_close (C function), 57
 mcc118_firmware_version (C function), 58
 mcc118_info (C function), 57
 mcc118_is_open (C function), 57
 mcc118_open (C function), 57
 mcc118_serial (C function), 58
 mcc118_trigger_mode (C function), 60
 MCC118DeviceInfo (C struct), 64
 MCC118DeviceInfo.AI_MAX_CODE (C var), 64
 MCC118DeviceInfo.AI_MAX_RANGE (C var), 64
 MCC118DeviceInfo.AI_MAX_VOLTAGE (C var), 64
 MCC118DeviceInfo.AI_MIN_CODE (C var), 64
 MCC118DeviceInfo.AI_MIN_RANGE (C var), 64
 MCC118DeviceInfo.AI_MIN_VOLTAGE (C var), 64
 MCC118DeviceInfo.NUM_AI_CHANNELS (C var), 64
 mcc128 (class in daqhats), 112
 mcc128_a_in_mode_read (C function), 67
 mcc128_a_in_mode_write (C function), 67
 mcc128_a_in_range_read (C function), 68
 mcc128_a_in_range_write (C function), 68
 mcc128_a_in_read (C function), 68
 mcc128_a_in_scan_actual_rate (C function), 69
 mcc128_a_in_scan_buffer_size (C function), 71
 mcc128_a_in_scan_channel_count (C function), 72
 mcc128_a_in_scan_cleanup (C function), 72
 mcc128_a_in_scan_read (C function), 71
 mcc128_a_in_scan_start (C function), 69
 mcc128_a_in_scan_status (C function), 71
 mcc128_a_in_scan_stop (C function), 72
 mcc128_blink_led (C function), 66
 mcc128_calibration_coefficient_read (C function), 66
 mcc128_calibration_coefficient_write (C function), 67
 mcc128_calibration_date (C function), 66
 mcc128_close (C function), 65
 mcc128_firmware_version (C function), 66
 mcc128_info (C function), 66
 mcc128_is_open (C function), 65
 mcc128_open (C function), 65
 mcc128_serial (C function), 66
 mcc128_trigger_mode (C function), 68
 MCC128DeviceInfo (C struct), 73
 MCC128DeviceInfo.AI_MAX_CODE (C var), 73
 MCC128DeviceInfo.AI_MAX_RANGE (C var), 73
 MCC128DeviceInfo.AI_MAX_VOLTAGE (C var), 73
 MCC128DeviceInfo.AI_MIN_CODE (C var), 73
 MCC128DeviceInfo.AI_MIN_RANGE (C var), 73
 MCC128DeviceInfo.AI_MIN_VOLTAGE (C var), 73
 MCC128DeviceInfo.NUM_AI_CHANNELS (C var), 73
 MCC128DeviceInfo.NUM_AI_MODES (C var), 73

MCC128DeviceInfo.NUM_AI_RANGES (C var), 73
mcc134 (class in daqhats), 122
mcc134_a_in_read (C function), 78
mcc134_calibration_coefficient_read (C function), 76
mcc134_calibration_coefficient_write (C function), 76
mcc134_calibration_date (C function), 76
mcc134_cjc_read (C function), 79
mcc134_close (C function), 75
mcc134_info (C function), 75
mcc134_is_open (C function), 75
mcc134_open (C function), 75
mcc134_serial (C function), 75
mcc134_t_in_read (C function), 78
mcc134_tc_type_read (C function), 77
mcc134_tc_type_write (C function), 77
mcc134_update_interval_read (C function), 77
mcc134_update_interval_write (C function), 77
MCC134DeviceInfo (C struct), 79
MCC134DeviceInfo.AI_MAX_CODE (C var), 80
MCC134DeviceInfo.AI_MAX_RANGE (C var), 80
MCC134DeviceInfo.AI_MAX_VOLTAGE (C var), 80
MCC134DeviceInfo.AI_MIN_CODE (C var), 80
MCC134DeviceInfo.AI_MIN_RANGE (C var), 80
MCC134DeviceInfo.AI_MIN_VOLTAGE (C var), 80
MCC134DeviceInfo.NUM_AI_CHANNELS (C var), 80
mcc152 (class in daqhats), 127
mcc152_a_out_write (C function), 82
mcc152_a_out_write_all (C function), 82
mcc152_close (C function), 82
mcc152_dio_config_read_bit (C function), 87
mcc152_dio_config_read_port (C function), 88
mcc152_dio_config_write_bit (C function), 85
mcc152_dio_config_write_port (C function), 86
mcc152_dio_input_read_bit (C function), 83
mcc152_dio_input_read_port (C function), 83
mcc152_dio_int_status_read_bit (C function), 85
mcc152_dio_int_status_read_port (C function), 85
mcc152_dio_output_read_bit (C function), 84
mcc152_dio_output_read_port (C function), 85
mcc152_dio_output_write_bit (C function), 84
mcc152_dio_output_write_port (C function), 84
mcc152_dio_reset (C function), 83
mcc152_info (C function), 82
mcc152_is_open (C function), 81
mcc152_open (C function), 81
mcc152_serial (C function), 82
MCC152DeviceInfo (C struct), 89
MCC152DeviceInfo.AO_MAX_CODE (C var), 89
MCC152DeviceInfo.AO_MAX_RANGE (C var), 89
MCC152DeviceInfo.AO_MAX_VOLTAGE (C var), 89
MCC152DeviceInfo.AO_MIN_CODE (C var), 89
MCC152DeviceInfo.AO_MIN_RANGE (C var), 89
MCC152DeviceInfo.AO_MIN_VOLTAGE (C var), 89
MCC152DeviceInfo.NUM_AO_CHANNELS (C var), 89
MCC152DeviceInfo.NUM_DIO_CHANNELS (C var), 89
mcc172 (class in daqhats), 140
mcc172_a_in_clock_config_read (C function), 94
mcc172_a_in_clock_config_write (C function), 95
mcc172_a_in_scan_buffer_size (C function), 97
mcc172_a_in_scan_channel_count (C function), 99
mcc172_a_in_scan_cleanup (C function), 99
mcc172_a_in_scan_read (C function), 98
mcc172_a_in_scan_start (C function), 96
mcc172_a_in_scan_status (C function), 98
mcc172_a_in_scan_stop (C function), 99
mcc172_a_in_sensitivity_read (C function), 93
mcc172_a_in_sensitivity_write (C function), 93
mcc172_blink_led (C function), 91
mcc172_calibration_coefficient_read (C function), 92
mcc172_calibration_coefficient_write (C function), 92
mcc172_calibration_date (C function), 92
mcc172_close (C function), 91
mcc172_firmware_version (C function), 91
mcc172_iepe_config_read (C function), 93
mcc172_iepe_config_write (C function), 93
mcc172_info (C function), 91
mcc172_is_open (C function), 91
mcc172_open (C function), 90
mcc172_serial (C function), 91
mcc172_trigger_config (C function), 95
MCC172DeviceInfo (C struct), 100
MCC172DeviceInfo.AI_MAX_CODE (C var), 100
MCC172DeviceInfo.AI_MAX_RANGE (C var), 100
MCC172DeviceInfo.AI_MAX_VOLTAGE (C var), 100
MCC172DeviceInfo.AI_MIN_CODE (C var), 100
MCC172DeviceInfo.AI_MIN_RANGE (C var), 100
MCC172DeviceInfo.AI_MIN_VOLTAGE (C var), 100
MCC172DeviceInfo.NUM_AI_CHANNELS (C var), 100
MCC_118 (daqhats.HatIDs attribute), 103
MCC_128 (daqhats.HatIDs attribute), 103
MCC_134 (daqhats.HatIDs attribute), 103
MCC_152 (daqhats.HatIDs attribute), 103
MCC_172 (daqhats.HatIDs attribute), 103

N

NOCALIBRATEDATA (daqhats.OptionFlags attribute), 104
NOSCALEDATA (daqhats.OptionFlags attribute), 104

O

OPEN_TC_VALUE (C macro), 79
OPEN_TC_VALUE (daqhats.mcc134 attribute), 122
OptionFlags (class in daqhats), 104
OPTS_CONTINUOUS (C macro), 55
OPTS_DEFAULT (C macro), 55

OPTS_EXTCLOCK (*C macro*), 55
 OPTS_EXTTRIGGER (*C macro*), 55
 OPTS_NOCALIBRATEDATA (*C macro*), 55
 OPTS_NOSCALEDATA (*C macro*), 55
 OUTPUT_TYPE (*daqhats.DIOConfigItem attribute*), 140
 OVERRANGE_TC_VALUE (*C macro*), 79
 OVERRANGE_TC_VALUE (*daqhats.mcc134 attribute*), 122

P

PULL_CONFIG (*daqhats.DIOConfigItem attribute*), 140
 PULL_ENABLE (*daqhats.DIOConfigItem attribute*), 140

R

ResultCode (*C enum*), 54
 ResultCode.RESULT_BAD_PARAMETER (*C enumerator*), 54
 ResultCode.RESULT_BUSY (*C enumerator*), 54
 ResultCode.RESULT_COMMS_FAILURE (*C enumerator*), 54
 ResultCode.RESULT_INVALID_DEVICE (*C enumerator*), 54
 ResultCode.RESULT_LOCK_TIMEOUT (*C enumerator*), 54
 ResultCode.RESULT_RESOURCE_UNAVAIL (*C enumerator*), 54
 ResultCode.RESULT_SUCCESS (*C enumerator*), 54
 ResultCode.RESULT_TIMEOUT (*C enumerator*), 54
 ResultCode.RESULT_UNDEFINED (*C enumerator*), 54
 RISING_EDGE (*daqhats.TriggerModes attribute*), 104

S

SE (*daqhats.AnalogInputMode attribute*), 121
 serial() (*daqhats.mcc118 method*), 106
 serial() (*daqhats.mcc128 method*), 114
 serial() (*daqhats.mcc134 method*), 123
 serial() (*daqhats.mcc152 method*), 129
 serial() (*daqhats.mcc172 method*), 142
 SLAVE (*daqhats.SourceType attribute*), 151
 SourceType (*C enum*), 100
 SourceType (*class in daqhats*), 151
 SourceType.SOURCE_LOCAL (*C enumerator*), 100
 SourceType.SOURCE_MASTER (*C enumerator*), 100
 SourceType.SOURCE_SLAVE (*C enumerator*), 100
 STATUS_BUFFER_OVERRUN (*C macro*), 56
 STATUS_HW_OVERRUN (*C macro*), 56
 STATUS_RUNNING (*C macro*), 56
 STATUS_TRIGGERED (*C macro*), 56

T

t_in_read() (*daqhats.mcc134 method*), 125
 tc_type_read() (*daqhats.mcc134 method*), 124
 tc_type_write() (*daqhats.mcc134 method*), 124
 TcTypes (*C enum*), 80

TcTypes (*class in daqhats*), 127
 TcTypes.TC_DISABLED (*C enumerator*), 81
 TcTypes.TC_TYPE_B (*C enumerator*), 81
 TcTypes.TC_TYPE_E (*C enumerator*), 80
 TcTypes.TC_TYPE_J (*C enumerator*), 80
 TcTypes.TC_TYPE_K (*C enumerator*), 80
 TcTypes.TC_TYPE_N (*C enumerator*), 81
 TcTypes.TC_TYPE_R (*C enumerator*), 80
 TcTypes.TC_TYPE_S (*C enumerator*), 80
 TcTypes.TC_TYPE_T (*C enumerator*), 80
 TEMPERATURE (*daqhats.OptionFlags attribute*), 104
 trigger_config() (*daqhats.mcc172 method*), 145
 trigger_mode() (*daqhats.mcc118 method*), 107
 trigger_mode() (*daqhats.mcc128 method*), 115
 TriggerMode (*C enum*), 56
 TriggerMode.TRIG_ACTIVE_HIGH (*C enumerator*), 56
 TriggerMode.TRIG_ACTIVE_LOW (*C enumerator*), 56
 TriggerMode.TRIG_FALLING_EDGE (*C enumerator*), 56
 TriggerMode.TRIG_RISING_EDGE (*C enumerator*), 56
 TriggerModes (*class in daqhats*), 104
 TYPE_B (*daqhats.TcTypes attribute*), 127
 TYPE_E (*daqhats.TcTypes attribute*), 127
 TYPE_J (*daqhats.TcTypes attribute*), 127
 TYPE_K (*daqhats.TcTypes attribute*), 127
 TYPE_N (*daqhats.TcTypes attribute*), 127
 TYPE_R (*daqhats.TcTypes attribute*), 127
 TYPE_S (*daqhats.TcTypes attribute*), 127
 TYPE_T (*daqhats.TcTypes attribute*), 127

U

update_interval_read() (*daqhats.mcc134 method*), 125
 update_interval_write() (*daqhats.mcc134 method*), 124

W

wait_for_interrupt() (*in module daqhats*), 102